

Physics A

Twenty First Century Science Suite

OCR GCSE in Physics A J635

Foreword to the Second Edition

This Second Edition of the OCR GCSE Physics A specification has been produced to correct minor errors found in the original edition (published in Dec 2005). There are no changes to actual content or the scheme of assessment. Centres should note however the grade descriptions in Appendix A have now been replaced with the correct versions.

Contents

1	About this Qualification	4
1.1	About the Twenty First Century Science Suite	4
1.2	About this Physics Specification	4
1.3	Qualification Titles and Levels	5
1.4	Aims	6
1.5	Prior Learning/Attainment	6
2	Summary of Content	7
3	Content	8
	Layout of Module Content	8
	Module P1: The Earth in the Universe – Overview	9
	Module P2: Radiation and Life – Overview	14
	Module P3: Radioactive Materials – Overview	19
	Module P4: Explaining Motion – Overview	24
	Module P5: Electric Circuits – Overview	29
	Module P6: The Wave Model of Radiation – Overview	35
	Module P7: Further Physics Observing the Universe – Overview	40
4	Scheme of Assessment	48
4.1	Units of Assessment	48
4.2	Unit Options	50
4.3	Tiers	50
4.4	Assessment Availability	50
4.5	Assessment Objectives	51
4.6	Quality of Written Communication	52
5	Skills Assessment	53
5.1	Nature of Skills Assessment	53
5.2	Marking Internally Assessed Work	55
5.3	Regulations for Internally Assessed Work	70
6	Technical Information	72
6.1	Making Unit Entries	72
6.2	Making Qualification Entries	72
6.3	Grading	73
6.4	Result Enquiries and Appeals	74
6.5	Shelf-Life of Units	74
6.6	Unit and Qualification Re-sits	74
6.7	Guided Learning Hours	74
6.8	Code of Practice/Subject Criteria/Common Criteria Requirements	74
6.9	Arrangements for Candidates with Particular Requirements	74
6.10	Prohibited Qualifications and Classification Code	75

7	Other Specification Issues	76
7.1	Overlap with other Qualifications	76
7.2	Progression from these Qualifications	76
7.3	ICT	76
7.4	Citizenship	77
7.5	Key Skills	77
7.6	Spiritual, Moral, Ethical, Social, Legislative, Economic and Cultural Issues	78
7.7	Sustainable Development, Health and Safety Considerations and European Developments	79
7.8	Avoidance of Bias	79
7.9	Language	80
7.10	Support and Resources	80
<hr/>		
Appendix A:	Grade Descriptions	81
Appendix B:	Requirements Relating to Mathematics	83
Appendix C:	Physical Quantities and Units	84
Appendix D:	Health and Safety	85
Appendix E:	Explanation of Terms Used in Module Content	86
Appendix F:	Ideas About Science	87
Appendix G:	Science Explanations	94
Appendix H:	Electrical Symbols	99

1 About this Qualification

1.1 About the Twenty First Century Science Suite

The Twenty First Century Science suite comprises six specifications which share common material, use a similar style of examination questions and have a common approach to skills assessment. The qualifications available as part of this suite are:

GCSE Science A (J630)	which emphasises scientific literacy – the knowledge and understanding which candidates need to engage, as informed citizens, with science-based issues. As with other courses in the suite, this qualification uses contemporary, relevant contexts of interest to candidates, which can be approached through a range of teaching and learning activities.
GCSE Additional Science A (J631)	which is a concept-led course developed to meet the needs of candidates seeking a deeper understanding of basic scientific ideas. The course focuses on scientific explanations and models, and gives candidates an insight into how scientists develop scientific understanding of ourselves and the world we inhabit.
GCSE Additional Applied Science A (J632)	which meets the needs of candidates who wish to develop their scientific understanding through authentic, work related contexts. The course focuses on procedural and technical knowledge that underpins the work of practitioners of science and gives candidates an insight into what is involved in being a practitioner of science.
GCSE Biology A (J633)	each of which provides an opportunity for further developing an understanding of science explanations, how science works and the study of elements of applied science, with particular relevance to professional scientists.
GCSE Chemistry A (J634)	
GCSE Physics A (J635)	

This suite is supported by the Nuffield Curriculum Centre and The University of York Science Education Group.

1.2 About this Physics Specification

This booklet contains OCR's GCSE specification in Physics for teaching from September 2006 and first certification in June 2008.

This specification aims to provide candidates with the scientific understanding needed to progress to further studies of physics, should they choose to undertake them. Candidates should gain an insight into:

- what is involved in being a practitioner of science;
- how scientists develop scientific understanding of ourselves and the world we inhabit;
- how these understandings can be applied to the benefit of humanity.

Candidates must have a broad understanding of the scientific ideas that provide a conceptual foundation for further studies of science. These are referred to as 'Science Explanations'. But, candidates also need to be able to reflect on scientific knowledge itself, the practices that have produced it, the kinds of reasoning that are used in developing a scientific argument, and on the

issues that arise when scientific knowledge is put to practical use. These are referred to as 'Ideas about Science' (IaS). This specification provides a combination of these two essential elements.

This specification comprises seven teaching modules which are assessed through four units. Candidates take Units 1, 2 and 3 **and** either Unit 4 **or** 5.

Unit	Unit Code	Title	Duration	Weighting	Total Mark
1	A331	Physics A Unit 1 – modules P1,P2, P3	40 mins	16.7%	42
2	A332	Physics A Unit 2 – modules P4, P5, P6	40 mins	16.7%	42
3	A333	Physics A Unit 3 – Ideas in Context plus P7	60 mins	33.3%	55
4	A339	Physics A Unit 4 – Practical Data Analysis and Case Study	-	33.3%	40
5	A340	Physics A Unit 5 – Practical Investigation	-	33.3%	40

1.3 Qualification Titles and Levels

This qualification is shown on a certificate as OCR GCSE in Physics.

This qualification is approved by the regulatory authority, QCA, as part of the National Qualifications Framework.

Candidates who gain grades G to D will have achieved an award at Foundation Level (Level 1 of the National Qualifications Framework).

Candidates who gain grades C to A* will have achieved an award at Intermediate Level (Level 2 of the National Qualifications Framework).

1.4 Aims

The aims of this GCSE specification are to encourage candidates to:

- acquire a systematic body of scientific knowledge, and the skills needed to apply this in new and changing situations in a range of domestic, industrial and environmental contexts;
- acquire an understanding of scientific ideas, how they develop, the factors which may affect their development and their power and limitations;
- plan and carry out investigative tasks, considering and evaluating critically their own data and that obtained from other sources, and using ICT where appropriate;
- use electronic (internet, CD ROMs, databases, simulations etc.) and/or more traditional sources or information (books, magazines, leaflets etc.) to research and plan an investigation.
- select, organise and present information clearly and logically, using appropriate scientific terms and conventions, and using ICT where appropriate;
- interpret and evaluate scientific data from a variety of sources;

1.5 Prior Learning/Attainment

Candidates who are taking courses leading to this qualification at Key Stage 4 should normally have followed the corresponding Key Stage 3 programme of study within the National Curriculum.

Other candidates entering this course should have achieved a general educational level equivalent to National Curriculum Level 3, or a distinction at Entry Level within the National Qualifications Framework.

2 Summary of Content

A module defines the required teaching and learning outcomes.

The specification content is displayed as nine modules. The titles of these nine modules are listed below.

Modules P1 - 6 are designed to be taught in approximately half a term, in 10% of the candidates' curriculum time. Module P7 is designed to be taught in approximately one and a half terms at 10% curriculum time.

Module P1: The Earth in the Universe

- What do we know about the Earth and Space?
- How have the Earth's continents moved, and with what consequences?
- What is known about stars and galaxies?
- How do scientists develop explanations of the Earth and Space?

Module P2: Radiation and Life

- What types of electromagnetic radiation are there? What happens when radiation hits an object?
- Which types of electromagnetic radiation harm living tissue and why?
- How does electromagnetic radiation make life on earth possible?
- What is the evidence for global warming? Why might it be occurring, and how serious a threat is it?
- What ideas about risk do citizens and scientists have?

Module P3: Radioactive Materials

- Why are some materials radioactive?
- How can radioactive materials be used and handled safely, including wastes?
- How should electricity be generated? What can be done with nuclear wastes?
- What are the health risks from radioactive materials?

Module P4: Explaining Motion

- How can we describe motion?
- What are forces?
- What is the connection between forces and motion?
- How can we describe motion in terms of energy changes?

Module P5: Electric Circuits

- Electric current – a flow of what?
- What determines the size of the current in an electric circuit?
- How do parallel and series circuits work?
- How is mains electricity produced?
- How much electrical energy do we use at home?

Module P6: The Wave Model of Radiation

- What are waves?
- Why do scientists think that light and sound are waves?
- Do all types of electromagnetic radiation behave in the same way?
- How is information added to a wave?

Module P7: Further Physics - Observing the Universe

- How do astronomers observe the sky?
- How does a telescope work?
- What are the objects we see in the night sky and how far away are they?
- What are stars?
- How do astronomers work together?

3 Content

Layout of Module Content

The specification content of modules P1, P2 and P3 is based on a set of Science Explanations and the Ideas about Science (see Appendices F and G). The presentation of the content of these modules recognises these ideas about science in the presentation of the synopsis page, which has a layout shown here.

Issues for citizens e.g. e.g. Is it safe to use mobile 'phones?	Questions that science may help to answer e.g. e.g. Which types of electromagnetic radiation harm living tissues and why?
Science Explanations e.g. e.g. SE 12 Radiation	Ideas about Science e.g. IaS 2.1, 2.3 - 2.7 Correlation and cause

The overview identifies:

- issues for citizens which are likely to be uppermost in the minds of citizens when considering the module topic, whatever their understanding of science;
- questions about the topic that science can help to address which could reasonably be asked of a scientifically literate person;
- those Science Explanations and Ideas about Science which are introduced or further developed in the module.

Modules P4, P5, P6 and P7 also begin with a synopsis page, which outlines the content of the module.

Some symbols and fonts are provided to give teachers additional information, expressed in abbreviated form, about the way in which the content is linked to other parts of the specification, and the table below summarises this information.

Abbreviation	Explanation and guidance
Bold	These content statements will only be assessed on Higher Tier papers.
①	Advisory notes for teachers to clarify depth of cover required.

MODULE P1: THE EARTH IN THE UNIVERSE – OVERVIEW

Scientific discoveries in the Solar System and beyond continue to inspire popular culture and affect our understanding of our place in the Universe. In this module, candidates learn about the life cycle of a star and its implications for the Sun and Earth. They also explore the scale of the Universe and its past, present and future, and consider whether we are alone or there might be life elsewhere.

Closer to home, candidates consider both long and short term changes in the Earth's crust, and how these changes impact on human life. A theme running through the module is natural disasters: earthquakes, volcanoes and asteroid impact - explaining them, predicting them and coping with or averting them.

Across the whole module, candidates encounter many examples showing relationships between data and explanations. Through these contexts they learn about the way scientists communicate and develop new explanations.

Issues for citizens	Questions that science may help to answer
Is there life elsewhere in the Universe?	What do we know about the Earth and space?
Why do mountains come in chains, in particular places? Can we predict earthquakes, especially those that are likely to cause most damage?	How have the Earth's continents moved, and with what consequences?
Could the human race be destroyed by an asteroid colliding with the Earth? What will happen to the Earth and the Sun?	What is known about stars and galaxies?
What do we know about the Universe? Where do the elements of life come from?	How do scientists develop explanations of the Earth and space?
Science Explanations	Ideas about Science
SE14 a, b The Earth SE15 The Solar System SE16 The Universe	1aS3 Developing explanations 1aS4 The scientific community

ICT Opportunities

This module offers opportunities for illustrating the use of ICT in science, for example:

- computer modelling of galaxies in collision;
- processing data on movements of the Earth's lithosphere (to confirm the theory of plate tectonics);
- creating a 3D model of the large-scale structure of the Universe from individual galaxy observations.

Use of ICT in teaching and learning can include:

- animations to illustrate continental drift and movement at tectonic plate margins;
- internet to research particular geohazard.

MODULE P1: THE EARTH IN THE UNIVERSE

P1.1 What do we know about the Earth and space?

1. recall that rocks provide evidence for changes in the Earth (erosion and sedimentation, fossils, folding, radioactive dating, craters);
2. understand that continents would be worn down to sea level, if mountains were not being continuously formed;
3. understand that the rock processes seen today can account for past changes;
4. understand that the Earth must be older than its oldest rocks, **which are about 4 thousand million years old**;
5. label on a given diagram of the Earth its crust, mantle and core;
6. recall that the solar system was formed over very long periods from clouds of gases and dust in space, **about 5 thousand million years ago**;
7. distinguish between planets, moons, the Sun, comets, asteroids and be aware of their relative sizes and motions;
8. recall that fusion of hydrogen **nuclei** is the source of the Sun's energy;
9. understand that all chemical elements larger than helium were made in earlier stars;
10. discuss the probability and possible consequences of an asteroid colliding with the Earth, including the extinction of the dinosaurs;
11. in relation to the above, or when provided with relevant additional information:
 - can identify statements which are data and statements which are (all or part of) an explanation;
 - can recognise data or observations that are accounted for by (or conflict with) an explanation;
 - can identify imagination and creativity in the development of explanations;
 - can justify accepting or rejecting a proposed explanation on the grounds that it:
 - accounts for observations;
 - **and/or provides an explanation that links things previously thought to be unrelated**;
 - **and/or leads to predictions that are subsequently confirmed**;
12. recall that light travels at a high but finite speed, **300 000 km/s**;
13. understand that the speed of light means distant objects are observed as younger than they are now;
14. recall a light-year is the distance travelled by light in a year;
15. compare the relative ages of the Earth, the Sun, and the Universe;
16. compare the relative diameters of the Earth, the Sun and the Milky Way;
17. relate uncertainty in the distance of stars and galaxies to the difficulty of observations.

MODULE P1: THE EARTH IN THE UNIVERSE

P1.2 How have the Earth's continents moved, and with what consequences?

1. recall Wegener's theory of continental drift and his evidence for it (geometric fit of continents and their matching fossils, mountain chains, and rocks);
2. understand how Wegener's theory accounted for mountain building;
3. recall reasons for the rejection of Wegener's theory by geologists of his time (movement of continents not detectable, Wegener an outsider to the community of geologists, too big an idea from limited evidence, simpler explanations of the same evidence);
4. understand that seafloor spreading is a consequence of movement of the solid mantle;
5. **recall that seafloors spread by about 10 cm a year;**
6. **understand how seafloor spreading produces a pattern in the magnetism recorded in ocean floors, limited to reversals of the Earth's magnetic field and solidification of molten magma at oceanic ridges;**
7. recall that earthquakes, volcanoes and mountain building generally occur at the edges of tectonic plates;
8. **understand how the movement of tectonic plates causes earthquakes, volcanoes, mountain building and contributes to the rock cycle;**
9. recall some actions that public authorities can take to reduce damage caused by geohazards.

MODULE P1: THE EARTH IN THE UNIVERSE

P1.3 What is known about stars and galaxies?

1. understand that what we know about distant stars and galaxies comes only from the radiation astronomers can detect;
2. understand that distance to stars can be measured using the relative brightness of stars or parallax (qualitative idea only);
3. understand that light pollution interferes with observations of the night sky;
4. recall that the Sun is a star in the Milky Way galaxy;
5. recall that there are thousands of millions of galaxies, each containing thousands of millions of stars, and that all of these make up the Universe;
6. recall that all stars have a life cycle;
7. recall that astronomers have detected planets around some nearby stars;
8. understand that, if even a small proportion of stars have planets, many scientists think that it is likely that life exists elsewhere in the Universe;
9. recall that no evidence of alien life (at present or in the past) has so far been detected;
10. recall that distant galaxies are moving away from us;
11. **relate the distance of galaxies to the speed at which they are moving away; (Hubble's law, but not redshift);**
12. **understand why the motions of galaxies suggests that Space itself is expanding;**
13. recall that the Universe began with a 'big bang' about 14 thousand million years ago;
14. understand why the ultimate fate of the Universe is difficult to predict.

MODULE P1: THE EARTH IN THE UNIVERSE

P1.4 How do scientists develop explanations of the Earth and Space?

1. in relation to movements of the Earth's continents (P1.2) or what is known about stars and galaxies (P1.3), or when provided with relevant additional information:
 - can identify statements which are data and statements which are (all or part of) an explanation;
 - can recognise data and observations that are accounted for by, (or conflict with), a given explanation;
 - can identify imagination and creativity in the development of an explanation;
 - can describe in broad outline the 'peer review' process, in which new scientific claims are evaluated by other scientists;
 - can recognise that new scientific claims which have not yet been evaluated by the scientific community are less reliable than well established ones;
2. in relation to movements of the Earth's continents (P1.2), or when provided with relevant additional information:
 - can justify accepting or rejecting a proposed explanation on the grounds that it:
 - accounts for observations;
 - **and/or provides an explanation that links things previously thought to be unrelated;**
 - **and/or leads to predictions that are subsequently confirmed;**
 - can draw valid conclusions about the implications of given data for a given explanation, e.g.
 - recognises that an observation that agrees with a prediction (derived from an explanation) increases confidence in the explanation **but does not prove it is correct;**
 - recognises that an observation that disagrees with a prediction (derived from an explanation) indicates that either the observation or the prediction is wrong, **and that this may decrease our confidence in the explanation;**
 - can identify a scientific question for which there is not yet an agreed answer, **and suggest a reason why;**
 - can identify absence of replication as a reason for questioning a scientific claim;
 - **can explain why scientists regard it as important that a scientific claim can be replicated by other scientists;**
 - can suggest plausible reasons why scientists involved in a scientific event or issue disagree(d);
 - **can suggest reasons for scientists' reluctance to give up an accepted explanation when new data appear to conflict with it.**

MODULE P2: RADIATION AND LIFE – OVERVIEW

The possible health risks of radiation, both in nature and from technological devices, are becoming of increasing concern. In some cases, misunderstanding the term ‘radiation’ generates unnecessary alarm. By considering the need to protect the skin from sunlight, candidates are introduced to a general model of radiation travelling from the source to a receiver. They learn about the electromagnetic spectrum and the harmful effects of some radiation. Through an investigation of evidence, concerning the possibly harmful effects of low intensity microwave radiation from devices such as mobile phones, candidates learn to evaluate reported health studies and interpret levels of risk. The greenhouse effect and photosynthesis illustrate how radiation from the Sun is vital to life, whilst the ozone layer is shown to be a natural protection from harmful radiation. Finally, candidates study evidence of global warming and its relationship to the carbon cycle. Possible consequences and preventative actions are explored.

Issues for citizens	Questions that science may help to answer
What is radiation?	What types of electromagnetic radiation are there? What can happen when radiation hits an object?
Is it safe to use mobile ‘phones? Is it safe to sunbathe?	Which types of electromagnetic radiation harm living tissues and why? What ideas about risk do citizens and scientists use?
Are there any benefits from radiation?	How does electromagnetic radiation make life on Earth possible?
What is global warming, and what can be done to prevent or reduce it?	What is the evidence for global warming, why might it be occurring, and how serious a threat is it?
Science Explanations	Ideas about Science
SE 12 Radiation SE 5a The chemical cycles of life SE14c The Earth	IaS 2.1, 2.3 - 2.7 Correlation and cause IaS 5 Risk

ICT Opportunities

This module offers opportunities for illustrating the use of ICT in science, for example:

- computer climate modelling;
- displaying data on stratospheric ozone concentrations as a false colour map.

Use of ICT in teaching and learning can include:

- PowerPoint slides to illustrate evidence of climate change;
- video clip to illustrate infra red imaging;
- animation to model Sun’s radiation and greenhouse effect
- animation to model effect of carbon dioxide levels on global temperature
- computer climate models

MODULE P2: RADIATION AND LIFE

P2.1 What types of electromagnetic radiation are there? What happens when radiation hits an object?

1. recall that light is one of a family of radiations, the electromagnetic spectrum;
2. understand that a beam of electromagnetic radiation delivers energy in 'packets' called photons
3. list the electromagnetic radiations in order of the energy delivered by each photon – radio waves, microwaves, infrared, ^{red} light ^{violet}, ultraviolet, X-rays, gamma rays;
4. interpret a situation in which one object affects another some distance away in terms of the general model of electromagnetic radiation:
 - one object (a source) emits radiation;
 - the radiation travels from the source and can be reflected, transmitted or absorbed by materials on its journey;
 - radiation may be absorbed by another object (a detector) some distance away;
5. understand that the energy deposited by a beam of electromagnetic radiation depends on both the number of photons arriving and the energy that each photon delivers;
6. recall that intensity of electromagnetic radiation is the energy arriving at a surface each second;
7. understand that the intensity of a beam of electromagnetic radiation decreases with distance **and be able to explain why**;
8. understand that ionising radiation is able to break molecules into bits (called ions), **which can then take part in other chemical reactions**;
9. recall that ionising radiation includes:
 - ultraviolet radiation;
 - X-rays;
 - gamma rays;
10. understand that microwaves heat materials containing particles that the microwaves can vibrate;
11. relate the heating effect of non-ionising radiation to its intensity **and duration**;
12. recall an example of the way in which each of infrared, microwaves and radio waves are used for transmitting information.

MODULE P2: RADIATION AND LIFE

P2.2 Which types of electromagnetic radiation harm living tissue and why?

1. recall that the heating effect of absorbed radiation can damage living cells;
2. recall that low intensity microwave radiation, for example from mobile phone hand sets and masts, may be a health risk, but this is disputed;
3. recall that ionising radiation can damage living cells;
4. recall examples of how exposure to different amounts of ionising radiation can affect living cells;
5. recall that the metal cases and door screens of microwave ovens protect users from the radiation;
6. recall that physical barriers protect people from ionising radiation, for example, sun-screens and clothing can be used to absorb most of the ultraviolet radiation from the Sun.

P2.3 How does electromagnetic radiation make life on Earth possible?

1. recall that the Earth is surrounded by an atmosphere which allows light radiated from the Sun to pass through;
2. recall that this radiation:
 - provides the energy for photosynthesis;
 - warms the Earth's surface;
3. recall that photosynthesis removes carbon dioxide from the atmosphere and adds oxygen, and that this reverses the effect of respiration;
4. understand that the Earth emits electromagnetic radiation that is absorbed by some gases in the atmosphere, so keeping the Earth warmer than it would otherwise be. This is called the greenhouse effect;
5. understand that the ozone layer absorbs ultraviolet radiation, **producing reversible chemical changes in that part of the atmosphere;**
6. understand that the ozone layer protects living organisms, especially animals, from the harmful effects ultraviolet radiation.

MODULE P2: RADIATION AND LIFE

P2.4 What is the evidence for global warming, why might it be occurring, and how serious a threat is it?

1. recall that one of the greenhouse gases in the Earth's atmosphere is carbon dioxide, present in small amounts;
2. **recall that other greenhouse gases include methane, present in trace amounts, and water vapour;**
3. interpret simple diagrams representing the carbon cycle;
4. use the carbon cycle to explain:
 - why for thousands of years the amount of carbon dioxide in the Earth's atmosphere was approximately constant;
 - how decomposers play an important part in the recycling of carbon;
 - that during the past two hundred years, the amount of carbon dioxide in the atmosphere has been steadily rising;
 - that the rise in atmospheric carbon dioxide is largely the result of:
 - burning increased amounts of fossil fuels as an energy source;
 - burning forests to clear land;
5. **understand that computer climate models provide evidence that human activities are causing global warming;**
6. understand that global warming could result in:
 - climate change and how this could make it impossible to continue growing some food crops in particular regions;
 - extreme weather conditions in some regions;
 - rising sea levels, due to melting continental ice and expansion of water in the oceans, which would cause flooding of low-lying land.

MODULE P2: RADIATION AND LIFE

P2.5 What ideas do citizens and scientists have about risk?

1. when provided with necessary additional information about alleged health risks due to radiation (P2.2) or global warming (P2.4) can:
 - identify examples of risk which arise from new scientific or technological advances;
 - suggest ways of reducing specific risks;
 - interpret and discuss information on the size of risks, presented in different ways;
 - **discuss a given risk, taking account of both the chance of it occurring and the consequences if it did;**
 - **identify, or propose, an argument based on the precautionary principle;**
 - use the ideas of correlation and cause appropriately when discussing historical events or topical issues in science;
 - **explain why a correlation between a factor and an outcome does not necessarily mean that one causes the other, and give an example to illustrate this;**
 - suggest factors that might increase the chance of an outcome, but not invariably lead to it;
 - explain that individual cases do not provide convincing evidence for or against a correlation;
 - **use data to develop an argument that a factor does/does not increase the chance of an outcome;**
 - **identify the presence (or absence) of a plausible mechanism as significant for the acceptance (or rejection) of a claimed causal link.**
2. When provided with necessary additional information about alleged health risks due to radiation emitted from technological devices, or ultraviolet radiation from the Sun (P2.2), can:
 - explain why it is impossible for anything to be completely safe;
 - suggest benefits of activities with known risk;
 - offer reasons for peoples willingness (or reluctance) to accept the risk of a given activity;
 - discuss personal and social choices in terms of a balance of risk and benefit;
 - **distinguish between actual and perceived risk, when discussing personal and social choices;**
 - **suggest reasons for given examples of differences between actual and perceived risk;**
 - **explain what the ALARA (as low as reasonably achievable) principle means, and how it applies in a given situation;**
 - identify the outcome and the factors that may affect it;
 - suggest how an outcome might be affected when a factor is changed;
 - give an example from everyday life of a correlation between a factor and an outcome;
 - evaluate the design for a study to test whether or not a factor increases the chance of an outcome, by commenting on sample size and how well the samples are matched.

MODULE P3: RADIOACTIVE MATERIALS – OVERVIEW

The terms 'radiation' and 'radioactivity' are often interchangeable in the public mind. Because of its invisibility, radiation is commonly feared. A more objective evaluation of risks and benefits is encouraged through developing an understanding of the many practical uses of radioactive materials.

Through the use of radioactive materials in the health sector, candidates learn about the nature of radioactivity, its harmful effect on living cells and how it can be handled safely. In the context of health risks associated with irradiation and/or contamination by radioactive material, they also learn about the interpretation of data on risk.

The UK Government may soon consult with the public about building new nuclear power stations. A key argument is that generating electricity from nuclear fission does not produce carbon dioxide. On the other hand, there is still no solution to the long-term problem of disposing of nuclear wastes. Renewable energy sources may not generate sufficient electricity to replace existing nuclear stations when these reach the end of their lifetimes.

Candidates consider different ways that electricity could be generated and different ways that nuclear wastes could be disposed of. These case studies illustrate that public decisions must be made by weighing up benefits against costs. Factors to consider include both technical feasibility and likely social and environment impact, now and in the future.

Issues for citizens	Questions that science may help to answer
What does 'radioactive' mean?	Why are some materials radioactive?
If radiation from radioactive materials is dangerous, how can it help to cure cancer?	What are the health risks from radioactive materials? How can radioactive materials be used and handled safely, including wastes?
Do we need nuclear power?	How can electricity be generated? What can done with nuclear waste?
Science Explanations	Ideas about Science
SE 11a,b,e Energy sources and uses SE 13 Radioactivity	IaS 5 Risk IaS 6.1-6.3, 6.7 Making decisions about science and technology

ICT Opportunities

This module offers opportunities for illustrating the use of ICT in science, for example:

- computer tomography used with gamma imaging;
- the role of computers in remote handling of highly radioactive waste.

Use of ICT in teaching and learning can include:

- datalogging to show decay of protactinium;
- animation to illustrate atomic structure and decay;
- video clips to illustrate key ideas of risk in context of radioactive materials;
- animation to illustrate key processes in power stations

MODULE P3: RADIOACTIVE MATERIALS

P3.1 Why are some materials radioactive?

1. recall that some elements emit ionising radiation all the time and are called radioactive;
2. understand that radioactive elements are naturally found in the environment, emitting background radiation;
3. recognise, in given text, the terms electron, proton, neutron and nucleus;
4. **understand that an atom has a nucleus, made of protons and neutrons;**
5. **understand that every atom of any element has the same number of protons but the number of neutrons may differ;**
6. understand that the behaviour of radioactive materials cannot be changed by chemical or physical processes;
7. recall three types of ionising radiation (alpha, beta and gamma) emitted by radioactive materials;
8. recall the penetration properties of each type of radiation;
9. **describe radioactive materials in terms of the instability of the nucleus, radiation emitted and the element left behind;**
10. understand that, over time, the activity of radioactive sources decreases;
11. understand the meaning of the term half-life;
12. understand that radioactive elements have a wide range of half-life values;
13. **carry out simple calculations involving half-life.**

MODULE P3: RADIOACTIVE MATERIALS

P3.2 How can radioactive materials be used and handled safely, including wastes?

1. understand that ionising radiation can damage living cells;
2. understand that ionising radiation is able to break molecules into bits (called ions), **which can then take part in other chemical reactions**;
3. understand that when ionising radiation strikes living cells these may be killed or may become cancerous;
4. recall how ionising radiation can be used to:
 - treat cancer;
 - sterilise surgical instruments;
 - sterilise food;
5. recall that radiation dose (in sievert) (based on both amount and type of radiation) is a measure of the possible harm done to your body;
6. interpret given data on risk related to radiation dose;
7. understand that radioactive materials expose people to risk by irradiation and contamination;
8. recall that we are irradiated and contaminated all the time and name some sources of this background radiation;
9. relate ideas about half life and background radiation to the time taken for a radioactive source to become safe;
10. recall categories of people who are regularly exposed to risk of radiation and that their exposure is carefully monitored.

MODULE P3: RADIOACTIVE MATERIALS

P3.3 How can electricity be generated? What can be done with nuclear wastes?

1. understand why electricity is called a secondary energy source;
2. understand that electricity is convenient because it is easily transmitted over distances and can be used in many ways;
3. label a block diagram showing the basic steps by which electricity is generated;
4. interpret a Sankey diagram of electricity generation and distribution to include the efficiency of energy transfers;
5. recall two examples to show that we can use renewable energy sources instead of fuels to generate electricity;
6. recall that power stations which burn carbon fuels will produce carbon dioxide;
7. understand that a nuclear fuel is one where energy is released from changes in the nucleus;
8. **know that in nuclear fission a neutron splits a large and unstable nucleus (limited to uranium) into two smaller parts, roughly equal in size, releasing more neutrons;**
9. **compare the amount of energy released during nuclear fission with that released in a chemical reaction;**
10. **understand how the nuclear fission process in nuclear power stations is controlled, and use the terms chain reaction, fuel rod, control rod and coolant;**
11. understand that nuclear power stations produce radioactive waste;
12. understand that nuclear wastes are categorised as high level, intermediate level and low level, and relate this to disposal methods;
13. Interpret and evaluate information about different energy sources for generating electricity, considering efficiency, economic and environmental costs, **power output and lifetime.**

MODULE P3: RADIOACTIVE MATERIALS

P3.4 What are the health risks from radioactive materials?

1. when provided with additional information on the health risks associated with radioactive materials, and the steps taken to limit these:
 - can explain why it is impossible for anything to be completely safe;
 - can identify examples of risks which arise from new scientific or technological advances;
 - can suggest ways of reducing specific risks;
 - can interpret and discuss information on the size of risks, presented in different ways;
 - **can discuss a given risk, taking account of both the chance of it occurring and the consequences if it did;**
 - can suggest benefits of activities with known risk;
 - can offer reasons for people's willingness (or reluctance) to accept the risk of a given activity;
 - can discuss personal and social choices in terms of a balance of risk and benefit;
 - **can identify, or propose, an argument based on the 'precautionary principle';**
 - **can distinguish between actual risk and perceived risk, when discussing personal and social choices;**
 - **can suggest reasons for given examples of differences between actual and perceived risk;**
 - **can explain what the ALARA (as low as reasonably achievable) principle means and how it applies to the issue in question;**
2. in the context of health risks associated with radioactive materials:
 - can identify the groups affected and the main benefits and costs of a course of action for each group;
 - can explain the idea of sustainable development, and apply it to specific situations;
 - shows awareness that scientific research and applications are subject to official regulations and laws;
 - **can distinguish what can be done (technical feasibility), from what should be done (values);**
 - **can explain why different courses of action may be taken in different social and economic contexts.**

MODULE P4: EXPLAINING MOTION – OVERVIEW

Simple but counterintuitive concepts of forces and motion, developed by Galileo and Newton, can transform young people's insight into everyday phenomena. These ideas also underpin an enormous range of modern applications, including spacecraft, urban mass transit systems, sports equipments and exciting rides at theme parks.

This module starts by looking at how speed is measured and represented graphically and the idea of velocity (as distinct from speed).

The second topic introduces the idea of forces: identifying, describing and using forces to explain simple situations. This is further developed in the third topic where resultant forces and changes in momentum are described.

The fourth and final topic considers the idea of work done by a force, gravitational potential energy and kinetic energy.

Topics

P4.1 How can we describe motion?

Calculation of speed; velocity; graphical representations of speed and velocity.

P4.2 What are forces?

The identification of forces and 'partner' forces.

P4.3 What is the connection between forces and motion?

Resultant forces and change in momentum; relating momentum to road safety measures.

P4.4 How can we describe motion in terms of energy changes?

Work done; changes in energy; GPE; KE; losses due to air resistance and friction.

ICT Opportunities

This module offers opportunities for illustrating the use of ICT in science, for example:

- computer programs that control the motion of spacecraft;
- use of computers for collecting, storing and displaying data on forces in simulated vehicle collisions;
- computer-enhanced use of radar to predict flight paths of aircraft.

Use of ICT in teaching and learning can include:

- video clips to provide contexts for learning about forces and motion;
- animation to illustrate interactive force pairs in various situations;
- animation to show the meaning of distance-time and other graphs;
- sensors and data loggers to collect measurements of movement for analysis;
- modelling software to analyse motion.

MODULE P4: EXPLAINING MOTION

P4.1 How can we describe motion?

1. apply the following equation to situations where an average speed is involved:

$$\text{speed} = \frac{\text{distance travelled (m)}}{\text{time taken (s)}} \quad (\text{m/s})$$

- ① Candidates should be able to apply the above equation to situations where an average speed is involved.
2. distinguish between average speed and instantaneous speed (in effect, an average over a short time interval) for examples of motion where speed is changing;
3. understand that distances measured in one direction are positive, and in the other, negative;
- ① Candidates are not expected to recall or use the term 'displacement'.
4. draw and interpret the shape of a distance-time graph for an object that is:
 - stationary;
 - moving at constant speed;
 - **moving with increasing or decreasing speed;**
5. interpret a steeper gradient of a distance-time graph as a higher speed;
6. **calculate a speed from the gradient of a straight section of a distance-time graph;**
7. recall that the velocity of an object at any instant is its speed plus an indication of the direction;
8. understand that the velocity of an object moving in a straight line is positive if it is moving in one direction and negative if it is moving in the opposite direction;
9. draw and interpret the shape of a velocity-time graph for an object that is:
 - stationary;
 - moving in a straight line with constant speed;
 - moving in a straight line with steadily increasing or decreasing speed;
10. relate these ideas about recording motion to applications such as lorry tachographs.

MODULE P4: EXPLAINING MOTION

P4.2 What are forces?

1. recall that a force arises from an interaction between two objects;
2. understand that when one object exerts a force on another, it always experiences a force in return;
3. in simple everyday situations:
 - identify forces arising from an interaction between two objects.
 - identify the 'partner' of a given force (i.e. the other force of the interaction pair);
 - specify, for each force, the object which exerts it, and the object on which it acts;
 - use arrows to show the sizes and directions of forces acting;
4. understand that the two forces in an interaction pair are equal in size and opposite in direction; and that they act on different objects;
5. recall that some forces (such as friction, reaction of a surface) arise in response to the action of an applied force;
6. describe the interaction between an object and a surface it is resting on: the object pushes down on the surface; the surface pushes up on the object with an equal force; this is called the reaction of the surface;
7. describe the interaction between two surfaces which slide (or tend to slide) relative to each other: each surface experiences a force in the direction which prevents (or tends to prevent) relative movement; this interaction is called friction;
- ① Candidates should be able to apply these ideas to explain situations such as walking, or the driving force on vehicles.
8. be able to use the idea of a pair of equal and opposite forces to explain in outline how rockets and jet engines work.

MODULE P4: EXPLAINING MOTION

P4.3 What is the connection between forces and motion?

1. be able to interpret situations in which several forces act on an object;
2. recall that the resultant force on an object is the sum of all the individual forces acting on it, taking their directions into account;
3. recall that if a resultant force acts on an object, it causes a change of momentum in the direction of the force;
4. use the definition:
 - momentum = mass × velocity
(kg m/s) (kg) (m/s)
5. understand that the size of the change of momentum is related to the size of the resultant force and the time for which it acts in the following way:
 - change of momentum = resultant force × time for which it acts
(kg m/s) (N) (s)
6. understand how the horizontal motion of objects (like cars and bicycles) can be analysed in terms of a driving force (produced by the engine or the cyclist), and a counter force (due to friction and air resistance);
7. recall that for a moving object, if the driving force is:
 - greater than the counter force, the vehicle will speed up;
 - equal to the counter force, the vehicle will move at constant speed in a straight line;
 - smaller than the counter force, the vehicle will slow down;
8. understand that, in situations involving a change in momentum (such as a collision), the longer the duration of the impact, the smaller the average force for a given change in momentum;
9. use this idea to discuss and explain the action of road safety measures, such as car seat-belts, crumple zones, air bags, cycle and motorcycle helmets;
10. understand that, if the resultant force on an object is zero, its momentum does not change (if it is stationary, it stays at rest; if it is already moving, it continues at a steady speed in a straight line).

MODULE P4: EXPLAINING MOTION

P4.4 How can we describe motion in terms of energy changes?

- recall that the energy of a moving object is called kinetic energy ;
- recall that as an object falls, its gravitational potential energy decreases;
- recall that when a force causes movement of an object, work is done;
- use the equation:
 - work done by a force = force \times distance moved by the force
(joule, J) (newton, N) (metre, m)
- understand that when work is done on an object, the energy of the object increases and when work is done by an object, the energy of the object decreases according to the relationship:
 - change in energy = work done;
(joule, J) (joule, J)
- understand that when an object is lifted to a higher position above the ground, work is done by the lifting force against the gravitational force acting on the object (its weight); this increases the object's gravitational potential energy (GPE);
- use the equation:
 - change in GPE = weight \times vertical height difference
(joule, J) (newton, N) (metre, m)
- understand that when a force acting on an object makes its velocity increase, the force does work on the object and this results in an increase in its kinetic energy;
- understand that the greater the mass of an object and the faster it is moving, the more kinetic energy it has;
- use the equation:
 - kinetic energy = $\frac{1}{2} \times$ mass \times [velocity]²
(joule, J) (kilogram, kg) (metre per second, m/s)²
- explain that if friction and air resistance can be ignored, an object's kinetic energy increases by an amount equal to the work done on it by an applied force;
- understand that air resistance or friction will cause the gain in an object's kinetic energy to be less than the work done on it by an applied force, because some energy is dissipated through heating;
- recall that energy is always conserved;
- calculate the gain in kinetic energy, **and the speed**, of an object that has fallen through a given height.

MODULE P5: ELECTRIC CIRCUITS – OVERVIEW

Known only by its effects, electricity provides an ideal vehicle to illustrate the use and power of scientific models. During the course of the 20th century electrical engineers completely changed whole societies, by designing systems for electrical generation and distribution, and a whole range of electrical devices.

In this module candidates learn how scientists visualise what is going on inside circuits and so predict circuit behaviour. The idea of current as a flow of electrons is introduced in the first topic. In the second topic, useful models of charge moving through circuits driven by a voltage and against a resistance, include that of a liquid in a narrow tube and a belt between pressure pads. A more general understanding of voltage as potential difference is developed in the third topic and a model based on height differences can be introduced.

The concepts of current and voltage are further developed in the topic on generation of electricity. The final topic relates these concepts to power, and introduces the idea of efficiency of electrical appliances.

Topics

P5.1 Electric current – a flow of what?

Electric current as a flow of charge; how the charge moves.

P5.2 What determines the size of the current in an electric circuit?

Voltage; current and resistance; series and parallel circuits; working out resistance.

P5.3 How do parallel and series circuits work?

Voltage and how it behaves in a series circuit; current and how it behaves in a parallel circuit.

P5.4 How is mains electricity produced?

Including voltages and currents; how generators work; ac and dc.

P5.5 How much electrical energy do we use at home?

The relationship between power, voltage and current; calculating the energy transferred and the efficiency of the transfer.

ICT Opportunities

This module offers opportunities for illustrating the use of ICT in science, for example:

- studying electric fields between charged particles and surfaces;
- using computer simulations to construct virtual circuits and test their behaviour.

Use of ICT in teaching and learning can include:

- modelling software to explore electric circuit theory
- animation to illustrate model of electric current as flowing charges

MODULE P5: ELECTRIC CIRCUITS

P5.1 Electric current - a flow of what?

1. explain that when two objects are rubbed together and become charged, electrons are transferred from one object to the other;
2. recall that there are repulsive forces between objects with similar charges, and attractive forces between objects with opposite charges;
3. explain simple electrostatic effects in terms of attraction and repulsion between charges;
4. recall that electrons are negatively charged;
5. recall that electric current is a flow of charge;
6. recall that electric current is measured in amperes;
7. explain that in an electric circuit the components and wires are full of charges that are free to move;
8. explain that when a circuit is made the battery causes these free charges to move, and that they are not used up but flow in a continuous loop;
9. recall that in metallic conductors an electric current is a movement of free electrons;
10. explain that in metal conductors there are lots of charges free to move but in an insulator there are few charges free to move.

MODULE P5: ELECTRIC CIRCUITS

P5.2 What determines the size of the current in an electric circuit?

1. recall that the larger the voltage of the battery in a given circuit, the bigger the current;
2. explain that components (for example resistors, lamps, motors) resist the flow of charge through them;
3. recall that the larger the resistance in a given circuit, the smaller the current will be;
4. recall that the resistance of connecting wires is so small that it can usually be ignored;
5. recall that resistors get hotter when electric current passes through them, **and that this heating effect is caused by collisions between the moving charges and stationary atoms in the wire;**
6. recall that this heating effect makes a lamp filament hot enough to glow;
7. describe how the resistance of an LDR varies with light intensity;
8. describe how the resistance of a thermistor (ntc only) varies with temperature;
9. recognise and use the electrical symbols for a cell, power supply, filament lamp, switch, LDR, fixed and variable resistor, thermistor, ammeter and voltmeter;
10. explain that two (or more) resistors in series have more resistance than one on its own, because the battery has to push charges through both of them;
11. explain that two (or more) resistors in parallel provide more paths for charges to flow along than one resistor on its own, so the total resistance is less and the current is bigger;
12. use the equation:
 - $$\text{resistance (ohm, } \Omega) = \frac{\text{voltage (volt, V)}}{\text{current (ampere, A)}}$$
- ① **Rearrangement of the equation is expected only on higher tier.**
13. describe in words, or using a sketch graph, how the current varies with voltage in components whose resistance stays constant.

MODULE P5: ELECTRIC CIRCUITS

P5.3 How do parallel and series circuits work?

1. describe how a voltmeter should be connected to measure the potential difference between any two chosen points;
2. recall that the voltage of a battery (measured in V) provides a measure of the 'push' of the battery on the charges in the circuit;
3. recall that potential difference is another term for voltage;
4. relate the potential difference between two points in the circuit to the energy transferred to, or from, a given amount of charge as it moves between these points;
5. describe the effect on voltage and current of adding further batteries in series **and in parallel** with original one;
6. understand that when several components are connected in series to a battery:
 - the current through each component is the same;
 - the potential differences across the components add up to the potential difference across the battery (**because the total energy transferred to each unit of charge by the battery must equal the amount transferred from it to other components**);
 - the potential difference is largest across the component with the greatest resistance, **because more energy is transferred by the charge passing through a large resistance than through a small one**;
7. recall that when several components are connected in parallel directly to a battery:
 - **the potential difference (voltage) across each component is equal to the potential difference of the battery**;
 - **the current through each component is the same as if it were the only component present**;
 - the total current from (and back to) the battery is the sum of the currents through each of the parallel components;
 - the current is largest through the component with the smallest resistance, **because the same battery voltage causes more current to flow through a smaller resistance than a bigger one**.

MODULE P5: ELECTRIC CIRCUITS

P5.4 How is mains electricity produced? How are voltages and currents induced?

Candidates will be assessed on their ability to:

1. recall that mains electricity is produced by generators;
2. recall that generators produce a voltage by a process called electromagnetic induction;
3. recall that when a magnet is moving into a coil of wire a voltage is induced across the ends of the coil;
4. recognise that if the ends of the coil are connected to make a closed circuit, a current will flow round the circuit;
5. recall that if the magnet is moving out of the coil, or the other pole of the magnet is moving into it, there is a voltage induced in the opposite direction.
6. explain that a changing magnetic field caused by changes in the current in one coil of wire can induce a voltage in a neighbouring coil;
7. describe the construction of a transformer as two coils of wire wound on an iron core;
8. recall that a transformer can change the size of an alternating voltage;
9. **be able to use the equation:**
$$\frac{V_p}{V_s} = \frac{N_p}{N_s}$$
10. describe how, in a generator, a magnet or electromagnet is rotated within a coil of wire to induce a voltage across the ends of the coil;
11. understand that the size of this induced voltage can be increased by:
 - increasing the speed of rotation of the magnet or electromagnet;
 - increasing the strength of its magnetic field;
 - increasing the number of turns on the coil;
 - placing an iron core inside the coil;
12. **describe how the induced voltage across the coil of a generator changes during each revolution of the magnet or electromagnet and explain that the current produced in an external circuit is an alternating current (a.c.);**
13. understand that the current from a battery is always in the same direction: it is a direct current (d.c.);
14. recall that mains electricity is an a.c. supply;
15. **explain that a.c. is used because it is easier to generate than d.c., and can be distributed more efficiently;**
16. recall that the mains supply voltage to our homes is 230 volts.

MODULE P5: ELECTRIC CIRCUITS

P5.5 How much electrical energy do we use at home?

1. explain that when electric charge flows through a component (or device), energy is transferred to the component;
2. recall that the power (in watt, W) is a measure of the rate at which an appliance or device transfers energy;
3. use the following equation to calculate energy transfer in joules and kilowatt-hours:
 - $$\begin{array}{rcl} \text{energy transferred} & = & \text{power} \quad \times \quad \text{time} \\ \text{(joule, J)} & & \text{(watt, W)} \quad \quad \text{(second, s)} \\ \text{(kilowatt hour, kWh)} & & \text{(kilowatt, kW)} \quad \text{(hour, h)} \end{array}$$
4. use the equation:
 - $$\begin{array}{rcl} \text{power} & = & \text{potential difference (voltage)} \times \text{current} \\ \text{(watt, W)} & & \text{(volt, V)} \quad \quad \text{(ampere, A)} \end{array}$$
- ① **Transformation of these equations is only required on the higher tier.**
5. know that a joule is a very small amount of energy, so a domestic electricity meter measures the energy transfer in kilowatt hours;
6. calculate the cost of electrical energy given the power, the time and the cost per kilowatt hour;
7. use the following equation in the context of different electrical appliances:
$$\text{efficiency} = \frac{\text{energy usefully transferred}}{\text{total energy supplied}} \times 100$$

MODULE P6: THE WAVE MODEL OF RADIATION – OVERVIEW

Wave behaviour explains a great many phenomena, both natural and artificial, for all waves have properties in common.

The first topic introduces a basic vocabulary for describing waves. Reflections and refractions of water serve as models for the behaviour of light and sound in the second topic. The third topic explores the electromagnetic spectrum, giving examples of properties and contemporary uses of different waves.

The final topic is a first step towards an understanding of modern communications systems.

Topics

P6.1 What are waves?

Transverse and longitudinal waves; frequency, wavelength, amplitude, wave speed.

P6.2 Why do scientists think that light and sound are waves?

Reflection; refraction; effect of the medium; behaviour of water waves related to sound and light waves.

P6.3 Do all types of electromagnetic radiation behave in the same way?

Wavelength and frequency of the parts of the electromagnetic spectrum; properties and uses of each part of the electromagnetic spectrum.

P6.4 How is information added to a wave?

Analogue and digital signals to carry information; the quality of each type of signal.

ICT Opportunities

This module offers opportunities for illustrating the use of ICT in science, for example:

- simulating the shape of wavefronts and interference effects in a variety of engineering applications;
- analysing wave reflections in seismic explorations.

Use of ICT in teaching and learning can include:

- video clips to show examples of wave motion;
- animation to show the behaviour of waves in ripple tanks;
- modelling software to investigate the implications of the wave equation;
- spreadsheets to model features of analogue and digital communications systems;
- sound files, which can be listened to, displayed graphically and modified to illustrate AM and FM modulation and the effects of noise.

MODULE P6: THE WAVE MODEL OF RADIATION

P6.1 What are waves?

1. recall that a wave consists of disturbances that transfer energy in the direction that the wave travels, without transferring matter;
2. describe the differences between a transverse and a longitudinal wave;
3. recall that the frequency of the waves, in hertz (Hz), is the number of waves each second that are made by the source, or that pass through any particular point in the medium;
4. recall that the wavelength of waves is the distance between the same point on two adjacent disturbances;
5. recall the amplitude of waves is the distance from the top of the crest or bottom of the trough to the undisturbed position;
6. draw and interpret diagrams showing the amplitude and the wavelength of waves;
7. use the equation:
 - $$\begin{array}{l} \text{wave speed} = \qquad \qquad \qquad \text{frequency} \quad \times \quad \text{wavelength} \\ \text{(metre per second m/s)} \quad \quad \text{(hertz, Hz)} \quad \quad \quad \text{(metre, m)} \end{array}$$
- ① **Rearrangement of the equation is only expected on higher tier.**
8. recall that the speed of a wave is usually independent of its frequency or amplitude.

MODULE P6: THE WAVE MODEL OF RADIATION

P6.2 Why do scientists think that light and sound are waves?

1. draw and interpret diagrams showing the reflection of plane water waves and narrow beams of sound or light from a plane reflector;
2. recognise that wave speed is affected by what waves are travelling along or through (the medium) and that the speed will change if a wave moves from one medium into another;
3. explain how a change in the speed of a wave causes a change in wavelength since the frequency of the waves cannot change, and that this may cause a change in direction;
4. draw and interpret diagrams showing the refraction of plane water waves, or beams of light or sound, when they cross a boundary between different media, relating the change of direction to the change in wave speed;
5. recall that the refraction of light waves and sound waves can be explained by a change in their speed when they pass into a different medium;
6. recall that light rays for which the angle of refraction would be greater than 90 degrees cannot leave the medium they are in, and are reflected and that this is known as total internal reflection;
7. recall that waves can spread out at a narrow gap and that this is called diffraction;
8. draw and interpret diagrams showing wave diffraction through gaps;
9. recall that light can be diffracted but needs a very small gap, comparable to the wavelength of the wave;
10. recall that where two waves meet, their effects add and that this is called interference;
11. recall that where two waves arrive in step they reinforce and where they arrive out of step they cancel out;
12. recall that two light beams can be shown to produce an interference pattern;
13. explain interference patterns in terms of constructive and destructive interference;
14. explain how the diffraction and interference of light and sound are evidence of their waves natures.

MODULE P6: THE WAVE MODEL OF RADIATION

P6.3 Do all types of electromagnetic radiation behave in the same way?

1. recall that the different colours of light in the spectrum have different frequencies (and therefore wavelengths);
2. list the parts of the whole electromagnetic spectrum in order of frequency or wavelength (radio waves, microwave, infrared, visible light, ultraviolet, X-rays, gamma radiation);
3. recall that the energy delivered by each photon in a beam of electromagnetic radiation increases with the frequency of the electromagnetic waves;
4. understand that the intensity of a beam of electromagnetic radiation (the energy it delivers per second) depends on the number of photons arriving every second and the amount of energy carried by each photon;
5. know that all types of electromagnetic radiation travel at exactly the same, very high, speed through space (a vacuum);
6. recall an important difference between electromagnetic waves and sound waves: electromagnetic waves can travel through empty space, but sound waves can only travel through a substance (solid, liquid or gas);
7. understand that different frequencies of electromagnetic radiation are used for different purposes due to the difference in reflection, absorption, or transmission by different materials to include:
 - radio waves are not strongly absorbed by the atmosphere so can be used to carry information for radio and TV programmes;
 - some microwaves are strongly absorbed by water molecules and so can be used to heat objects containing water;
 - satellite dishes are made of metal because metals reflect microwaves well;
 - X-rays are absorbed by dense materials so can be used to produce shadow pictures of bones in our bodies or of objects in aircraft passengers' luggage;
 - light and infrared radiation can be used to carry information along optical fibres because they travel through without becoming significantly weaker.

MODULE P6: THE WAVE MODEL OF RADIATION

P6.4 How is information added to a wave?

1. recall that signals can be carried not only by radio waves and microwaves through the Earth's atmosphere and through space but also by light waves and infrared waves through optical fibres;
2. understand that if a wave is to carry information the waves must be made to vary in amplitude or frequency, and that the information is carried by the pattern of the variation, recall that this process is called modulation;
3. interpret diagrams showing how a sound wave can be used to vary the amplitude or frequency of a radio wave, with a pattern that matches its own frequency;
4. recall that a signal which varies continuously is called an analogue signal;
5. recall that the job of the receiver is to reproduce the original sound from the pattern of the variation;
- ① Details of any transmission or receiver systems are not required.
6. recall that sound (or other information) can be transmitted digitally (digital signal);
7. recall that, in digital transmission, the sound is often converted into a digital code made up from just two symbols (0 and 1);
8. recall that this coded information can be used to control the short bursts of waves (pulses) produced by a source (0 = no pulse, 1 = pulse);
9. recall that when the waves are received, the pulses are decoded to produce a copy of the original sound wave;
10. know that an important advantage of digital signals over analogue signals is that they can transmit information with higher quality, i.e. the signal is less affected by the transmission process;
11. understand that all signals, as they travel, decrease in intensity (their amplitude becomes smaller), so they may have to be amplified;
12. know that random additions to the original signal (noise) may be picked up as a signal travels, reducing its quality;
13. know that, when a signal is amplified, any noise it has picked up is also amplified;
14. understand that, with digital signals, 'on' and 'off' states can usually still be recognised despite any noise that is picked up. The signal can therefore be 'cleaned up' to remove the noise and restore the original pattern of 'on's and 'off's';
15. be able to use these ideas to interpret information about analogue and digital transmission **and to explain why information can be transmitted digitally with higher quality.**

MODULE P7: FURTHER PHYSICS OBSERVING THE UNIVERSE – OVERVIEW

More than ever before, Physics in the Twenty First Century has become an example of international cooperation, particularly in the areas of astronomy and cosmology. Astronomers work in a number of different ways. Some design new instruments for detecting photons across the full electromagnetic spectrum, some are involved directly in the planning, construction and operation of large telescopes, and others analyse the information obtained from robotic telescopes across the Earth or in orbit.

The module is in five sections: Observing the sky with the naked eye, Telescopes, Stars and Galaxies, the Birth and Death of Stars, and the Astronomical Community.

This module should emphasise the size and location of telescopes and the way in which astronomers obtain, share and use the information obtained from them. It provides the opportunity for a case study of the working of an astronomy group in the UK or overseas and allows candidates to obtain and discuss astronomical images either by direct observation or using the many images obtained from the websites of major observatories.

The last section incorporates an opportunity for a case study and a closing poster session on an astronomical topic chosen by the candidate. This is used to highlight aspects of Ideas about Science, IaS4: The Scientific Community. Candidates present and debate information that they have researched, as is done in scientific conferences.

Throughout the module candidates have opportunities to employ Ideas about Science from IaS1 Data and its limitations, IaS3 Developing explanations, and IaS4 Scientific community.

Topics

P7.1 Observing the sky with the naked eye.

Observations of stars, planets and satellites.

P7.2 How does a telescope work?

Making a real image with a converging lens and the use of a second lens to create a telescope.

P7.3 What are the objects we see in the night sky and how far are they?

Spectra and brightness of stars; parsec; Cepheid variables; Hubble constant.

P7.4 What are stars?

Birth and death of stars; nuclear processes.

P7.5 How do astronomers work together?

Working with telescopes.

ICT Opportunities

This module offers opportunities for illustrating the use of ICT in science, for example:

- remote control of telescopes;
- the collection, storage and analysis of astronomical data.

Use of ICT in teaching and learning can include:

- the internet to find out about astronomy done at telescopes around the world and to view astronomical images;
- processing of astronomical images;
- learning from simulations and applets showing star processes.

MODULE P7: FURTHER PHYSICS OBSERVING THE UNIVERSE

P7.1 Observing the sky with the naked eye.

1. recall that the Sun appears to travel east-west across the sky once every 24 hours; that the stars appear to travel east-west across the sky once in a very slightly shorter time period (**23 h 56 min**); that the Moon appears to travel east-west across the sky once in a slightly longer time period (**about 25 hours**), and that the naked-eye planets (Mercury, Venus, Mars, Jupiter and Saturn) appear to move with the stars but change their positions in complicated patterns;
2. explain the apparent motions of Sun, stars, Moon **and planets** in terms of rotation of the Earth and the orbits of the Earth, Moon **and planets**;
3. explain the phases of the Moon in terms of the relative positions of the Sun, Moon and Earth;
4. explain eclipses in terms of the positions of the Sun and Moon **and explain the low frequency of eclipses in terms of the relative tilt of the orbits of the Moon about the Earth and the Earth about the Sun**;
5. explain that the positions of astronomical objects are measured in terms of angles as seen from Earth;
6. explain why a sidereal day, a rotation of 360° of the Earth, is different from a solar day due to the orbital movement of the Earth **and that a sidereal day is 4 minutes less than a solar day**;
7. explain why different stars are seen in the night sky at different times of the year, in terms of the movement of the Earth and the sun;
8. recall that planets move in complicated patterns relative to the 'fixed' stars.

MODULE P7: FURTHER PHYSICS OBSERVING THE UNIVERSE

P7.2 How does a telescope work?

1. recall that convex/converging lenses bring parallel light to a focus;
2. recall that more powerful lenses of the same material have more curved surfaces;
3. calculate the power of a lens from:
$$\text{power} = \frac{1}{\text{focal length}}$$

(diopetre) (metre)
4. draw and interpret diagrams showing the formation of a real image of a distant point source (off the principal axis of a lens) and of a distant extended source;
5. understand that astronomical objects are so distant that light from them is effectively parallel;
6. recall that a simple telescope has two converging lenses of different powers, with the more powerful lens as the eyepiece;
7. **calculate the angular magnification of a telescope from the powers of the two lenses using:**
$$\text{magnification} = \frac{\text{focal length of objective lens}}{\text{focal length of eyepiece lens}}$$
8. recall that most astronomical telescopes have concave mirrors, not convex lenses, as their objectives;
9. understand how concave mirrors bring parallel light to a focus.

MODULE P7: FURTHER PHYSICS OBSERVING THE UNIVERSE

P7.3 What are the objects we see in the night sky and how far away are they?

1. explain how parallax makes some stars seem to move relative to others over the course of a year;
2. define the parallax angle of a star as half the angle moved against a background of distant stars in 6 months;
3. explain that a smaller parallax angle means that the star is further away;
4. define a parsec (pc) as the distance to a star with a parallax angle of one second of arc;
5. calculate distances in parsecs for simple parallax angles expressed as fractions of a second of arc;
6. recall that a parsec is similar in magnitude to a light-year;
7. recall that typical interstellar distances are a few parsecs;
8. recall that the intrinsic brightness of a star depends on its temperature and its size;
9. explain qualitatively why the observed brightness of a star (as seen on Earth) depends on its intrinsic brightness and its distance from Earth;
10. recall that Cepheid variable stars pulse in brightness, with a period related to their brightness;
11. explain qualitatively how this relationship enables astronomers to estimate the distance to Cepheid variable stars;
12. understand the role of observations of Cepheid variable stars in establishing the scale of the Universe and the nature of most nebulae as distant galaxies. (IAS 1.3, 1, 4);
13. recall that telescopes revealed that the Milky Way consists of very many stars and led to the realisation that the Sun was a star in the Milky Way galaxy;
14. recall that telescopes revealed the existence of many fuzzy objects in the night sky, and that these were originally called nebulae;
15. recall the main issue in the Curtis-Shapley debate: whether nebulae were objects within the Milky Way or separate galaxies outside it;
16. recall that Hubble's observations of Cepheid variables in one nebula indicated that it was much further away than any star in the Milky Way, and hence that this nebula was a separate galaxy;
17. recall that intergalactic distances are typically measured in megaparsecs (Mpc);
18. recall that Cepheid variable data in distant galaxies has given accurate values of the Hubble constant;
19. use the following equation to calculate, given appropriate data, the speed of recession, **the Hubble constant and the distance to distant galaxies:**

$$\begin{array}{ccccc} \text{speed of recession} & = & \text{Hubble constant} & \times & \text{distance} \\ (\text{km/s}) & & (\text{s}^{-1}) & & (\text{km}) \end{array}$$

MODULE P7: FURTHER PHYSICS OBSERVING THE UNIVERSE

P7.4 What are stars?

1. recall that all hot objects (including stars) emit a continuous range of electromagnetic radiation, whose total intensity and peak frequency increases with temperature;
2. recall that the removal of electrons from atoms is called ionisation and that electron movement within atoms produces line spectra;
3. recall that the spectrum of a star also contains some specific spectral lines, and that these provide evidence of the chemical elements present in it;
4. use data on the spectrum of a star, together with data on the line spectra of elements, to identify elements present in it;
5. recall that when the volume of a gas is reduced its pressure increases and be able to explain this using a molecular model;
6. explain why the pressure or volume of a gas varies with temperature and interpret absolute zero using a molecular model;
7. recall that -273°C is the absolute zero of temperature, and be able to convert temperatures in K to temperatures in $^{\circ}\text{C}$ (and vice versa);
8. explain the formation of a protostar in terms of the effects of gravity compressing a cloud of gas;
9. understand that nuclear processes discovered in the early 20th Century provided a possible answer to the mystery of the Sun's energy source;
10. explain that compressing the gas, e.g. in a protostar, will raise its temperature;
11. describe the results of the Rutherford-Geiger-Marsden alpha particle scattering experiment as indicating that a gold atom contains a small, massive, positive region (the nucleus);
12. recall that the nucleus contains positive protons and neutral neutrons;
13. explain that protons are held together in the nucleus by a strong force much greater than the repulsive electrical force between them;
14. recall that hydrogen nuclei can fuse into helium nuclei, releasing energy, if brought close together;
15. recall that a star contains: a hotter core, where fusion takes place; a convective zone, where energy is transported to the surface by convection; the photosphere, where energy is radiated into space;
16. understand that all stars change when there is insufficient hydrogen in the core for fusion to continue;
17. recall that small stars like our Sun become red giants when the core hydrogen is depleted, while larger stars become red supergiants;
18. understand that red giants and red supergiants liberate energy by fusing helium into larger nuclei such as carbon, nitrogen and oxygen;
19. explain that red giants lack the mass to compress the core further at the end of the helium fusion, and they then shrink into hot white dwarfs, which gradually cool;

20. explain that fusion in red supergiants continues to larger nuclei due to the higher pressures in the core;
21. recall that fusion in large stars ceases when the core has been largely converted into iron, and the star then explodes in a supernova, leaving a dense neutron star or black hole.

MODULE P7: FURTHER PHYSICS OBSERVING THE UNIVERSE

P7.5 How do astronomers work together?

Candidates will be assessed on their ability to:

1. recall two examples of the location of major astronomical observatories;
2. explain that large telescopes are needed to collect the weak radiation from faint or very distant sources;
3. **explain that radiation is diffracted by the aperture of a telescope, and that the aperture must be very much larger than the wavelength of the radiation detected by the telescope to produce sharp images;**
4. describe two ways in which astronomers work with local or remote telescopes;
5. explain the advantages of computer control in remote telescopes;
6. explain the main advantages and disadvantages of using telescopes outside the Earth's atmosphere
 - avoids absorption and refraction effects of atmosphere;
 - can use parts of electromagnetic spectrum that the atmosphere absorbs;
 - cost of setting up, maintaining and repairing;
 - uncertainties of space programme;
7. understand the need for international collaboration in terms of economy and pooling of expertise;
8. describe one example showing how international cooperation is essential for progress in expensive 'big science' projects such as astronomy;
9. describe two astronomical factors that influence the choice of site for major astronomical observatories;
10. understand that non-astronomical factors:
 - cost;
 - environmental and social impact near the observatory;
 - working conditions for employees;are important considerations in planning, building, operating, and closing down an observatory.

4 Scheme of Assessment

4.1 Units of Assessment

GCSE Physics (J635)

Unit 1: Physics A Unit 1 – modules P1, P2, P3 (A331)

16.7% of the total GCSE marks
40 minutes written paper
42 marks

This question paper:

- is offered in Foundation and Higher Tiers;
- focuses on modules P1, P2 and P3;
- uses objective style questions throughout (there is no choice of questions).
- assesses knowledge and understanding of the specification content and application of that knowledge and understanding.

Unit 2: Physics A Unit 2 – modules P4, P5, P6 (A332)

16.7% of the total GCSE marks
40 minutes written paper
42 marks

This question paper:

- is offered in Foundation and Higher Tiers;
- focuses on modules P4, P5 and P6;
- uses objective questions throughout (there is no choice of questions).
- assesses knowledge and understanding of the specification content and application of that knowledge and understanding.

Unit 3: Physics A Unit 3 – Ideas in Context (A333)

33.3% of the total GCSE marks
60 minutes written paper
55 marks

This question paper:

- incorporates pre-release material
- assesses knowledge and understanding of the specification content and application of that knowledge and understanding
- uses structured questions throughout (there is no choice of questions).
- the subject focus of the pre-release material will normally be one or two of modules P1 to P6, the precise focus will be clear from the stimulus material.
- the remaining questions will be focused on the content of P7 Further Physics.
- includes some marks for communication skills.

Unit 4: Physics A Unit 4 – Practical Data Analysis and Case Study (A339)

33.3% of the total GCSE marks
skills assessment
40 marks (16 + 24)

- This skills assessment unit comprises two elements: the critical analysis of primary data and a case study of a topical (scientific) issue.
- Opportunities for both elements should arise naturally during the course.
- This unit is assessed by teachers, internally standardised and then externally moderated by OCR.

Unit 5: Physics A Unit 5 – Practical Investigation (A340)

33.3% of the total GCSE marks
skills assessment
40 marks

- This unit comprises five strands, which together are used to assess a complete investigative task.
- This unit is assessed by teachers, internally standardised and then externally moderated by OCR.

4.2 Unit Options

Candidates take Units 1, 2 and 3 **and** either Unit 4 **or** Unit 5.

4.3 Tiers

Units 1, 2 and 3 are set in one of two tiers: Foundation Tier and Higher Tier. Foundation Tier papers assess Grades G to C and Higher Tier papers assess Grades D to A*. An allowed grade E may be awarded on the Higher Tier components. Candidates are entered for either the Foundation Tier or the Higher Tier using option codes F and H.

Unit 4 and 5 (skills assessment) are not tiered. Candidates enter either A339 Practical Data Analysis task plus a Case Study, or A340 a Practical Investigation.

Candidates may enter Units 1, 2, and 3 at different tiers, so for example, a candidate may take A331F, A332F and A333H.

4.4 Assessment Availability

There are two examination sessions each year, in January and June.

	Unit 1 (A331)	Unit 2 (A332)	Unit 3 (A333)	Unit 4 (A339)	Unit 5 (A340)
January 2007	-	-	-	-	-
June 2007	✓	-	-	-	-
January 2008	✓	✓	-	-	-
June 2008	✓	✓	✓	✓	✓

After June 2008, Units A331 and A332 will be available in the January and June sessions. The Physics Ideas in Context paper, (Unit A333) and skills assessment, (Units A339 and A340), will only be available in the June sessions.

The Foundation and Higher tier papers covering the same unit will be timetabled on the same day, and will commence at the same time. The papers timetabled simultaneously will contain common questions, or part questions, targeting the overlapping grades C and D.

4.5 Assessment Objectives

The Assessment Objectives describe the intellectual and practical skills which candidates should be able to demonstrate, in the context of the prescribed content. Candidates should demonstrate communication skills, including ICT, using scientific conventions (including chemical equations) and mathematical language (including formulae).

Assessment Objective 1 (AO1): Knowledge and understanding of science and how science works

Candidates should be able to:

- demonstrate knowledge and understanding of the scientific facts, concepts techniques and terminology in the specification;
- show understanding of how scientific evidence is collected and its relationship with scientific explanations and theories;
- show understanding of how scientific knowledge and ideas change over time and how these changes are validated.

Assessment Objective 2 (AO2): Application of skills knowledge and understanding

Candidates should be able to:

- apply concepts, develop arguments or draw conclusions related to familiar and unfamiliar situations;
- plan a scientific task, such as a practical procedure, testing an idea, answering a question or solving a problem;
- show understanding of how decisions about science and technology are made in different situations, including contemporary situations and those raising ethical issues;
- evaluate the impact of scientific developments or processes on individuals, communities or the environment.

Assessment Objective 3 (AO3): Practical, enquiry and data-handling skills

Candidates should be able to:

- carry out practical tasks safely and skillfully;
- evaluate the methods they use when collecting first-hand and secondary data;
- analyse and interpret qualitative and quantitative data from different sources;
- consider the validity and reliability of data in presenting and justifying conclusions.

Weighting of Assessment Objectives

All figures given are for guidance only and have a tolerance of $\pm 3\%$.

Assessment Objectives	Weighting
AO1: Knowledge and understanding	30.0%
AO2: Application of knowledge and understanding, analysis and evaluation	40.6%
AO3: Enquiry	29.3%

The relationship between the components and the assessment objectives of the scheme of assessment is shown in the following grid.

	Weighting of Assessment Objectives by Unit			
	AO1	AO2	AO3	Total
Unit 1 (A331), Unit 2 (A332)	15%	16.3%	2.0%	33.3%
Unit 3 (A333)	13%	18.3%	2.0%	33.3%
Unit 4 (A339) Unit 5 (A340)	2%	6%	25.3%	33.3%
Overall	30%	40.6%	29.3%	100%

4.6 Quality of Written Communication

Candidates are expected to:

- ensure that text is legible and that spelling, punctuation and grammar are accurate so that meaning is clear;
- present information in a form that suits its purpose;
- use a suitable structure and style of writing.

Candidates quality of written communication will be assessed in the Ideas of Context (A333) and in the Case Study (A339) or Practical Investigation (A340).

5 Skills Assessment

5.1 Nature of Skills Assessment

Rationale

The skills assessment accounts for 33.3% of the marks for this specification. There is some choice of the material that is presented for assessment. However it is hoped that candidates have opportunities to develop their skills in all aspects of the tasks described here and then present the highest scoring piece of work.

Skills assessment should arise naturally out of teaching, so that it can be assessed by teachers, internally standardised and then externally moderated by OCR. Candidates are required to submit work for either Unit 4 (A339) or Unit 5 (A340).

Practical Data Analysis and Case Study (Unit 4, A339)

The Unit 4 skills assessment comprises two elements: the critical analysis of primary data, and a Case Study on a topical (scientific) issue.

First-hand experience of the problems of collecting valid and reliable data can give candidates a better sense of what the difficulties really are, a 'feel' for how great they are in specific cases, and provide a context for beginning to understand how to tackle and perhaps overcome them. Analysis and interpretation of data teaches how scientists use experimental evidence to develop and test theories. Evaluation of procedures and data shows how the reliability of scientific findings can be assessed.

The Case Study is designed to motivate candidates and give them an insight into how science is reported to the public, and how they can explore the validity of underlying research and claims or recommendations based on the research. Centres should note that marks for both elements of Unit 4 (A339) must be submitted in the same examination session.

Element 1: Data Analysis: Marks submitted out of 16

Candidates either singly or collaboratively take part in a practical procedure in order to collect primary data. Candidates are assessed on their ability to analyse and evaluate the data collected and the limitations of the techniques used. It is not essential for candidates to collect all of the data which is to be used in this exercise. Their own first hand data may be supplemented with extra data from other candidates or classes, demonstrations or other sources.

Marks are awarded for two strands, Interpretation (Strand I) and Evaluation (Strand E). The two marks which make up the assessment total for this element of skills assessment must both come from the same activity.

Element 2: Case Study Marks submitted out of 24

This assignment should arise naturally from work on the course or from an issue that arises while candidates are following the course. It should be related to an aspect of science that involves an element of controversy, in terms either of the interpretation of evidence, or of the acceptability of some new development. Topics for study should be selected by candidates in discussion with teachers, and should be seen as an extension or consolidation of studies undertaken as a normal part of the course. The work should be capable of being completed within approximately 4-6 hours

over a period of time, for example, one lesson per week for half a term, with some non-contact time.

Practical Investigation (Unit 5, A340)

The use of practical investigations to assess skills in science was based on research in a number of centres, particularly the University of Durham. For more than 10 years, it has formed the basis of coursework assessment for National Curriculum science.

Investigations require the drawing together of skills in planning, collecting data, interpreting data and evaluation. They provide an effective and valid assessment instrument for a course which is seen as a basis for further studies and possible future careers in science. However, the regulations used at Key Stage 4 over the past 5-year cycle have been constructed in a way which has restricted the variety of work attempted and has led to rather mechanical 'criterion matching', rather than genuine open-ended work.

For this specification, the basic structure of investigations is retained, but the emphasis on prediction is removed, allowing a much wider range of activities and approaches. A different marking style has been developed, drawing more on the professional judgment of teachers.

The task aims to motivate candidates and help them to appreciate the importance of having a clear and manageable question, to learn how to choose equipment and use it appropriately, and to design suitable apparatus for making observations and measurements. First-hand experience of the problems of collecting valid and reliable data can give candidates a better sense of what the difficulties really are, and a 'feel' for how great they are in specific cases, and provide a context for beginning to understand how to tackle and perhaps overcome these.

Candidates are required to complete one single practical investigation. The Investigation, accounts for 33% of the marks for this specification. It is assessed by teachers, internally standardised, and then externally moderated.

Within this science suite, investigative work is designed to have a broader and more open definition than in the National Curriculum Programme of Study Sc1.2. In addition to confirming the predicted effect of a variable on a system over a range, the definition also includes more speculative investigation of systems where no clear prediction can be made in advance, e.g. where there is little relevant explanatory theory available in the course, or where the experimental material is likely to be variable, for example in surveys of distribution of species. It also includes tasks which involve determining the consistency of measurements e.g. comparing the characteristics of different artefacts, obtaining evidence for the 'normal' variation in respiratory peak flow-rates of an individual, etc.

The initial stimulus for an investigation should arise from class teaching or discussion which ensures that candidates are aware of suitable practical techniques and have some relevant background theoretical knowledge.

This component of the assessment is based on complete, first hand practical investigations. Candidates may complete as many investigations as they wish during the course. The final mark will be the total for the highest-scoring single piece of work assessed. It is not permitted to aggregate together marks taken from different investigations. Where appropriate, first hand data collected by the candidate may be supplemented by secondary data from other sources. In such cases, credit for collecting data should be based on the overall quality of all the data obtained or selected.

Marks are awarded for 5 strands of the investigation, with each strand marked on a scale of 0 – 8.

5.2 Marking Internally Assessed Work

Arrival at Strand Marks

The method of marking the skills assessment is the same across this Science suite.

The award of marks is based on the professional judgement of the science teacher, working within a framework of descriptions of performance. Within each strand, each line in the marking grids represents a different aspect of performance. For each of these, a series of four descriptions of performance illustrates what might be expected for candidates working at different levels.

Marking decisions should be recorded on marking grids. A master copy is provided in the skills assessment guidance booklet. The completed grid serves as a cover-sheet for the work if it is required for moderation.

Candidates may not always report their work in a particular order. So, evidence of achievement in a strand may be located almost anywhere in the work. Thus, it is necessary to look at the whole piece of work for evidence of each strand in turn.

Within any one strand, each aspect should be considered in turn. A tick on the grid should be used to indicate the performance statement that best matches the work.

Where the maximum mark is 8, intermediate marks 1, 3, 5 or 7 can be used where performance exceeds that required by one statement, but does not adequately match that required by the next higher statement (e.g. if the work significantly exceeds what is required for 4 marks, but does not reach the standard for 6, then the tick should be placed on the dividing line between the 4 and 6 mark boxes).

Where a decision is based partly on the teacher's observation of the candidate at work, the work should be annotated to record this at an appropriate point.

In some cases, in order to allow credit for the widest possible variety of activities, an aspect of performance is represented by two (or more) rows of mark descriptors. In such cases, where a row is not relevant or appropriate for a particular activity, it should be left blank and excluded from the 'best-fit' marking judgement and the more appropriate alternative row used.

When each aspect of the performance within a strand have been assessed in this way, the pattern of achievement is interpreted by a 'best-fit' judgement to give a mark for that strand.

This method of marking can be applied even where there is a wide variation between performance in different aspects. Thus, weak performance in one aspect need not depress marks too far if other aspects show better performance.

Recording and submitting marks

Skills Assessment Forms will be provided for centres to record marks submitted for moderation. The final mark should be submitted to OCR on form MS1 by 15th May in the year of entry. These forms are produced and dispatched at the relevant time, based on entry information provided by the Centre.

All assessed work which has contributed to candidates' final totals must be available for moderation.

Unit 4 (A339), Element 1: Practical Data Analysis (13.3%)

Marking Criteria – Practical Data Analysis

There are two strands in this element; Interpreting Data and Evaluation. The descriptors for each strand are identical to those found in Unit 5 Practical Investigation (A340).

Strand I: Interpreting Data

Candidates are expected to be able to:

- present or process a set of data in such a manner as to bring out any ‘patterns’¹ that are present (laS1.4, 2.1, 2.3-4);
- state conclusions based on these patterns (laS 2.4);
- relate their conclusions to scientific theories or understanding (laS 3.1, 3.3, 3.4).

Aspect of Performance	Strand I Mark			
	2	4	6	8
a graphical or numerical processing of data	Display limited numbers of results in tables, charts or graphs, using given axes and scales.	Construct simple charts or graphs to display data in an appropriate way, allowing some errors in scaling or plotting.	Correctly select scales and axes and plot data for a graph, including an appropriate line (normally a line of best fit) or construct complex charts or diagrams (e.g. stacked histograms, species distribution maps).	Additionally, indicate the spread of data (e.g. through scatter-graphs or error bars) and give clear keys for displays involving multiple data sets.
	Select individual results as a basis for conclusions.	Carry out simple calculations (e.g. correct calculation of averages from repeated readings).	Use mathematical comparisons between results to support a conclusion.	Use complex processing to reveal patterns in the data (e.g. statistical methods, use of inverse relationships or calculation of gradient of graphs).
b summary of evidence	Note differences between situations/cases, or compare individual results.	Identify trends or general correlations in the data.	Describe formal or statistical relationships within the cases/situations studied.	Review the extent of, or limitations to, formal conclusions in relation to the scatter evident in the data.
c explanations suggested	Link the outcomes to previous experience or ‘common sense’.	Relate the conclusion to scientific ideas/explanations.	Justify the conclusion by reference to relevant scientific knowledge and understanding.	Use detailed scientific knowledge to explain all aspects of the given conclusion.

¹ ‘Patterns’ here means similarities, or differences, or the presence or absence of a relationship (e.g. a correlation between a factor and an outcome, or a trend linking two variables)

Strand E: Evaluation

Candidates are expected to be able to look back at the experiment they have carried out, showing what they have learned from doing it and explaining how they would modify it in the light of this, were they to carry it out again. These suggestions may demonstrate understanding of:

- difficulties in collecting valid and reliable data (IaS 1.1-3);
- weaknesses in the design of the data set collected, such as imperfect control of other variables, or the size and matching of samples compared (IaS 2.3, 2.6-7);
- assessing the level of confidence that can be placed in these conclusions (IaS 2.2-3, 2.6-7).

In the following table, each row represents increasing achievement in a different aspect of performance.

Aspect of Performance	Strand E Mark			
	2	4	6	8
a evaluation of procedures	Make a relevant comment about how the data was collected and about safety procedures.	Comment on the limitations to accuracy or range of data imposed by the techniques and equipment, used.	Suggests improvements to apparatus or techniques, or alternative ways to collect the data, but without sufficient practical detail.	Describe in detail improvements to the apparatus or techniques, or alternative ways to collect the data, and explain why they would be an improvement.
b reliability of evidence	Make a claim for accuracy or reliability, but without appropriate reference to the data.	Note the presence or absence of results that are beyond the range of experimental error.	Use the general pattern of results or degree or scatter between repeats as a basis for assessing accuracy and reliability.	Consider critically the reliability of the evidence, accounting for any anomalies.
c reliability of conclusion	Relate judgement of the reliability (or otherwise) of the conclusions only to techniques used, not to data collected.	Link confidence in the conclusion to the apparent reliability of the data collected.	Discuss the precision of apparatus and techniques, the range covered and reliability of data to establish a level of confidence in the conclusions.	Identify weaknesses in the data and give a detailed explanation of what further data would help to make the conclusions more secure.

Unit 4 (A339), Element 2: Case Study

The candidate presents one Case Study, a report based on detailed study of a chosen topic.

Choosing a topic

In everyday life, citizens most often become aware of science-related issues through reports in the media: newspapers, teenage magazines, television, etc. This component of the assessment is designed to help candidates develop strategies for evaluating such information, and to increase awareness of appropriate ways of making decisions about such issues.

Ideally, the study should arise from such a media source. Suitable topics involve some degree of controversy, or disagreement, either about the interpretation of the scientific evidence, or about how individuals or society should respond. The title for a Case Study is best phrased as a question to be answered by careful balancing of evidence and opinions from a variety of sources.

Suitable topics often fall into one of three main types:

- Evaluating claims where there is uncertainty in scientific knowledge (e.g. “Is there life elsewhere in the Solar System?” or “Does using mobile phones cause risk of brain damage?”) Controversies of this type focus attention on the relationship between data and explanations in science, and on the quality of research which underlies competing claims.
- Contributing to decision making on a science-related issue (e.g. “Should the government restrict research into human cloning?”) Studies in this category are more likely to involve elements of personal choice, values and beliefs, and may involve balancing of risks and benefits of any proposed action.
- Personal or social choices (e.g. “Should my child receive the triple MMR vaccine?”). Ethical and personal issues are likely to figure in such studies, but it is important to evaluate these in relation to what is known about the science which underlies the issue.

In all cases, an important factor in choice of subject should be the availability of information giving a variety of views in forms that can be accessed by the candidate. Candidates may be provided with the initial stimulus for the study, but should be encouraged to search for a range of opinions in order to reach a balanced conclusion.

The subject need not be restricted to topics studied in the course. However, it is necessary for the candidate to apply some relevant scientific knowledge and understanding to discussion of the issues raised. This is most likely to be the case if the study arises naturally during normal work on the course.

Candidates need not all study the same, or related, topics. Motivation is greatest if they are given some degree of autonomy in the choice of topic. This may be achieved by allowing choice of different issues related to a general topic (e.g. different aspects of global warming when studying Radiation and Life) or by encouraging candidates to identify topics of interest and begin collecting resource materials over an extended period. At a time chosen by the centre, candidates then complete their Case Study, and may each be working on different topics.

Presentation of the Case Study

Candidates will find it helpful to have a clear sense of audience in their writing – perhaps candidates in year 9, to encourage them to explain the basic science behind the topic.

The Case Study will often take the form of a 'formal' written report. However, candidates should not be discouraged from other styles of presentation, for example:

- a newspaper or magazine article;

- a PowerPoint presentation;
- a poster or booklet;
- a teaching/learning activity such as a game;
- a script for a radio programme or play.

In all cases, sufficient detail must be included to allow evaluation in all of the performance areas. Some types of presentation would require supporting notes.

A case study represents a major piece of work and it is not expected that candidates will attempt more than one during the two years of the course. If a candidate has attempted more than one case study, then the total for the assessment should be the highest total for any one case study.

It is not permitted to aggregate marks from two or more different pieces of work, nor to add marks obtained from separate, limited range tasks, exercises or part-studies.

Marking Criteria – Case Study

Marks are awarded under four headings, A, B, C and D.

Because of the risk of some studies becoming excessively long, it is important to link marks to the quality of the work done, rather than the quantity.

The four strands to be awarded credit are:

A: Quality of selection and use of information, on a scale of 0-4marks;

Here candidates should show an awareness of sources of information such as their own notes, text books or encyclopedias, or the internet. They should consider the reliability of any sources used. All sources should be credited, and it should be clear where each piece of information has come from. Credit is given for being selective in choosing only relevant material. Direct quotations should be acknowledged.

B: Quality of understanding of the case, on a scale of 0-8 marks;

Candidates should describe the basic science which helps understanding of the topic, and apply it to evaluate the reliability of claims made. In many cases, they may follow a topic beyond the normal limits of the specification, and credit should be awarded for understanding whether within or beyond the specification.

C: Quality of conclusions, on a scale of 0-8 marks;

Different evidence, arguments or views should be compared and evaluated and used as a basis for a balanced conclusion or proposal for action.

D: Quality of presentation, on a scale of 0-4 marks.

Communication skills should be rewarded for effective presentation including use of different forms for presenting different types of information (e.g. pictures, tables, charts, graphs, etc).

Strand A: Quality of Selection and Use of Information

Candidates will select and organise information from a variety of sources, bearing in mind both relevance to the study and the apparent reliability of the sources. It is expected that centres will make at least a basic selection of resources available for candidates to work from. A survey of the units included in the course will identify topics which are likely to be relevant, topical and of interest to candidates. In addition to standard textbooks and library books, resources are available from industry, from environmental groups and in popular science magazines, as well as through the internet.

Candidates should be encouraged to seek out their own additional resources, but should not be completely dependent on this, and in particular, should not be dependent on home or out of school support.

Credit will be given for selection of appropriate material from the available resources, rather than indiscriminate copying. It will also be given for judgement shown in selecting from a variety of sources to give a balanced view of the topic. Good work is characterised by the ability of the candidate to adapt and re-structure information to suit the purpose of the study.

In some cases, candidates may wish to collect information about the public acceptability of an idea or perception of risk through questionnaires (administered to classmates or other groups) or to test media claims through experimental work. Whilst relevant work of these types may be credited, it should not dominate the study.

In all cases, candidates should record the sources of information they have used. The assignment can be used as an introduction to the value of crediting sources in scientific communication.

Candidates should show awareness of the variety of sources of information relevant to science-based issues, and some understanding that the reliability of sources may vary.

This aspect of the work is linked to understanding of Ideas-about-Science 4: The Scientific Community (mainly IaS 4.1, 4.2, 4.3 and 4.4).

Aspect of Performance	Strand A Mark			
	2	4	6	8
a planning the use of sources of information	Very little information is given beyond that provided by the original stimulus material.	Information from a limited range of additional sources is included, although some may be irrelevant or inappropriate to the study.	Relevant information is selected from a variety of sources.	Sources of information are assessed for reliability as a basis for selection of relevant information from a wide variety of sources.
b acknowledgement of sources used.		Sources are identified by incomplete or inadequate references.	References to sources are clear, but limited in detail.	References to these sources are clear and fully detailed.
c linking information to specific sources		Direct quotations are rarely indicated as such.	Direct quotations are generally acknowledged.	The sources of particular opinions or information are indicated at appropriate points in the text of the report.

Strand B: Quality of Understanding of the Case

Where possible, candidates should make reference to explanatory scientific theory to help them understand the significance of the information they are dealing with. However, controversies in science often arise in areas where there is no (GCSE level) descriptive theory to provide a basis for understanding and evaluating the issues involved. In such cases, candidates should draw on Ideas about Science, especially IaS 2 (Correlation and cause), to justify the conclusions they reach about the information they have collected.

Note that these studies should not be used to extend or assess the candidate's knowledge of basic academic theory related to the topic, but rather to encourage them to see how the science knowledge they have can be related to topical issues to help them reach valid judgements. Some candidates may wish to go beyond what they have been taught in class and, if they find and correctly apply theory which is directly relevant to the Case Study, this can help to raise their mark. However, credit should not be given to uncritical copying of large amounts of theory from texts.

Candidates should provide some background to the case study in relation to relevant scientific theory. They should also evaluate how well-founded are links between the available evidence and claims or views made on the basis of the evidence. Where little explanatory theory is available at this level, candidates should draw on Ideas about Science 2, 3 and 4 to help them evaluate the evidence they find.

This aspect of the work depends on understanding of:

Ideas about Science 1: Data and its limitations (mainly 1.2, 1.3 and 1.4);

Ideas about Science 2: Correlation and cause (mainly 2.1, 2.2, 2.4 - 2.7).

Aspect of Performance	Strand B Mark			
	2	4	6	8
a making use of science explanations	Only superficial mentions of science explanations, often not correctly applied to the case	Provides a basic outline of the main scientific ideas which are relevant to the case.	Provides a detailed review of the scientific knowledge needed to understand the issues studied.	Considers how different views described in the study can be supported by detailed scientific explanations.
b recognition and evaluation of scientific evidence.	Sources are uncritically quoted without distinguishing between scientific evidence and unsupported claims.	Science content and data in sources is recognised.	Claims and opinions are linked to the scientific evidence they are based on.	The quality of scientific evidence in sources is evaluated in relation to the reliability of any claims made.

Strand C: Quality of Conclusions

The work should take account of different views or opinions which are represented in the information collected. Credit will be given for discussion of the perceived benefits and associated risks of any proposed actions, and for judgements of the acceptability of any conclusions reached.

The case studied should be such that there is scope for taking views about the acceptability of some view or course of action.

Work on this aspect of the Case Study will be linked to understanding of:

Ideas about Science 1: Data and its limitations (mainly parts 1.2 and 1.4);

Ideas about Science 5: Risk (mainly parts 5.1, 5.2, 5.4, 5.6 and 5.7);

Ideas about Science 6: Making decisions about science and technology (mainly parts 6.3, 6.4, 6.5 and 6.6).

Aspect of Performance	Strand C Mark			
	2	4	6	8
a comparing opposing evidence and views	Information is unselectively reported without taking any clear view about any course of action.	Claims for a particular idea, development or course of action are reported without critical comment.	Claims and arguments for and against are reported, but with little attempt to compare or evaluate them.	Details of opposing views are evaluated and critically compared.
b conclusions and recommendations	A conclusion is stated without reference to supporting evidence.	A conclusion is based on evidence for one view only.	Some limits or objections to the conclusion are acknowledged.	Alternative conclusions are considered, showing awareness that different interpretations of evidence may be possible.

Strand D: Quality of Presentation

Candidates should be encouraged to be creative and imaginative in their choice of method and media for communicating their findings. The report may be in a variety of forms, including formal written reports, newspapers, PowerPoint presentations, posters for a campaign, scripts for radio programmes or plays etc.

Whatever form of presentation is chosen, it should be supported by sufficient documentation to allow assessment of all four qualities. It should also be remembered that the work may need to be posted to a moderator towards the end of the course. Where electronic media are included, a paper print-out must be provided for moderation purposes.

Note that quality and fitness for purpose should be rewarded in the assessment, rather than the sheer quantity of the work.

Where written reports are given, candidates should be encouraged to structure the report clearly. An attractive cover helps to improve motivation and make the work “special”, thinking about a good structure for the contents can help candidates to organise their ideas. Use of tables of contents, and sub-headings between sections of text are valuable in this context.

Illustrations should be used where they lead to clearer communication of ideas. These may be taken from resource leaflets or ‘clip-art’ sources, or drawn by candidates: they may be pictorial or graphical. Tables, charts and graphs should be used to present and summarise data. Reports may be hand-written or word-processed.

Candidates should be encouraged to think carefully of their target audience and how to communicate their ideas clearly.

Aspect of Performance	Strand D Mark			
	1	2	3	4
a structure and organisation of the report	The report has little or no structure or coherence, or follows a pattern provided by worksheets.	The report has an appropriate sequence or structure.	Information is organised for effective communication of ideas, with contents listing, page numbering etc as appropriate to aid location of key elements.	Considerable care has been taken to match presentation and format to present issues and conclusions clearly and effectively to a chosen audience.
b use of visual means of communication	There is little or no visual material (charts, graphs, pictures, etc) to support the text.	Visual material is merely decorative, rather than informative.	Visual material is used to convey information or illustrate concepts.	Pictures, diagrams, charts and or tables are used appropriately and effectively to convey information or illustrate concepts
c spelling, punctuation and grammar	Spelling, punctuation and grammar are of generally poor quality, with little or no use of appropriate technical or scientific vocabulary.	Spelling, punctuation and grammar are of variable quality, with limited use of appropriate technical or scientific vocabulary.	Spelling, punctuation and grammar are generally sound, with adequate use of appropriate technical or scientific vocabulary.	The report is concise, with full and effective use of relevant scientific terminology. Spelling, punctuation and grammar are almost faultless.

Unit 5 (A340), Practical Investigation

This component is designed to test the ability of the candidate to plan and undertake a whole investigation or problem-solving task. Scoring individual marks in different tasks, or parts of tasks, removes this holistic element, and can result in performances of very different quality leading to the same final assessment total. For this reason, the final component mark for each candidate will be the highest total mark achieved on any one task. This total mark is obtained by adding together the marks achieved on each strand of the work on that task.

The requirement is for the highest mark from a single piece of work. It is not essential for this to be complete, in the sense of providing evidence across all strands. It may happen that some candidates achieve their highest total for a piece of work in which evidence for one or more strands is missing; in such cases this total should be chosen as the final assessment total.

Centres may assess the performance of candidates on any occasion when investigative work is taking place throughout the course.

Marking Criteria – Practical Investigation

Strand S: Strategy

Practical investigations are likely to arise out of work on most or all of the course modules. Suitable tasks might be suggested to candidates, but they should also have opportunities to modify or extend these, or to suggest questions or tasks to investigate in topic areas they are studying. Candidates can (and should) obtain more credit for tackling somewhat more demanding tasks, and for being involved in devising the question/task, rather than 'playing safe' with a given, or routine task, or one involving little skill in the use of equipment.

Whilst candidates should be encouraged to plan an investigation before starting, there is limited value in requiring them to produce a detailed written plan – as their actions should be open to modification as they proceed. Indeed, it is good practice to try taking a few measurements or making a few observations to get a 'feel' for the equipment and the system being investigated, before planning a detailed data collection strategy. For that reason, the candidate's understanding of issues concerning data is better assessed from the final data set they present (see strand C below), rather than from an initial plan.

Assessment of the quality of strand S focuses on –

- the complexity and demand of the task and approach chosen
- the choice of equipment, materials and techniques
- the degree of independence shown in formulating the task and the approach to it.

Aspect of Performance	Strand S Mark			
	2	4	6	8
a complexity and demand of task	Simple measurement or comparison task, based on straightforward use of simple equipment.	Routine task requiring only limited precision or range of data to be collected.	Straightforward task of limited complexity, but requiring good precision or a wide range of data.	Complex task requiring high levels of precision/reliability in the data collected.
b techniques used	Follow a given technique, but with very limited precision or reliability.	Select and use basic equipment to collect a limited amount of data.	Select and use techniques and equipment which are appropriate for the range of data required.	Justify the choice of equipment and technique to achieve data which is precise and reliable.
c autonomy and independence	The task has been set by the teacher and/or is based on specific, task-related structured worksheets.	The task is closely defined by the teacher, but is carried out with little further guidance.	The task is defined by the candidate from a more general brief, then carried out independently.	The topic is reviewed by the candidate to justify a choice of task. The work is completed independently.

Strand C: Collecting Data

Candidates are expected to be able to collect a set of data in a manner which shows understanding of how to ensure (and assess) quality.

The quality of a data set depends on:

- the quality of individual data points, which in turn depends on:
 - how carefully the measurements have been taken, and how accurate the available instruments are (laS 1.1-2);
 - how much variation or scatter there is in repeated measurements and the steps that have been taken to assess and deal with this (laS 1.1-4);
 - whether the instruments used, or the way they are used, results in measurements that differ from the 'true' value of the quantity (laS 1.1-2).
- the extent and design of the set of data points collected, that is:
 - whether enough data points have been collected (laS 2.1, 2.3, 2.7);
 - whether these cover an adequate range (of cases, or situations, or values of an independent variable) (laS 2.3);
 - (if a relationship is being explored) whether the design of the data set enables the effect of other variables to be excluded (for example (laS 2.2-3, 2.6-7).

Candidates should use preliminary experiments or other information to confirm that their choices of techniques and range of values to be tested will lead to results of good quality.

The statements are written to refer to primary data that the candidate has collected. Where this is supported by data from secondary sources, the statements should be read as referring to the data 'selected' (as opposed to 'collected'). The mark awarded should be based on all of the data considered as a whole.

Aspect of Performance	Strand C Mark			
	2	4	6	8
a identification and control of interfering factors	Little or no care has been taken to identify or control outside influences.	Identifies some factors which may affect the outcomes and need to be controlled or accounted for,	Identifies the majority of factors which may affect the outcomes and need to be controlled or accounted for.	Reviews factors which might affect the outcomes and describes how they have been controlled or account for.
b extent and design of data set	The data is very limited in amount (e.g. isolated individual data points, with no clear pattern), covering only part of the range of relevant cases/ situations, with no checking for reliability.	An adequate amount or range of data is collected, but with little or no checking for reliability.	Data is collected to cover the range of relevant cases/ situations, with regular repeats or checks for reliability.	Values tested are well-chosen across the range, with regular repeats and appropriate handling of any anomalous results. Preliminary tests are used to establish the range.
c quality/ precision of manipulation	Little care evident in use of apparatus. Data generally of low quality.	Use of techniques and apparatus generally satisfactory. Data of variable quality, with some operator error apparent.	Sound techniques in use of apparatus/ equipment. Data of generally good quality.	Consistent precision and skill shown in use of apparatus/ equipment. Where appropriate, checks or preliminary work are included to confirm or adapt the apparatus or techniques to ensure data of high quality.

Strand I: Interpreting Data

Candidates are expected to be able to:

- present or process a set of data in such a manner as to bring out any ‘patterns’² that are present (IaS1.4, 2.1, 2.3-4);
- state conclusions based on these patterns (IaS 2.4);
- relate their conclusions to scientific theories or understanding (IaS 3.1, 3.4, 3.5).

Aspect of Performance	Strand I Mark			
	2	4	6	8
a graphical or numerical processing of data	Display limited numbers of results in tables, charts or graphs, using given axes and scales.	Construct simple charts or graphs to display data in an appropriate way, allowing some errors in scaling or plotting.	Correctly select scales and axes and plot data for a graph, or construct complex charts or diagrams (e.g. histograms, bar charts, species distribution maps, scatter-grams).	Construct graphs or charts to show general relationships (e.g. line of best fit) or uncertainty (e.g. error bars) as appropriate.
	Select individual results as a basis for conclusions.	Carry out simple calculations e.g. correct calculation of averages from repeated readings.	Use mathematical comparisons between results to support a conclusion	Use complex processing to reveal patterns in the data e.g. statistical methods, use of inverse relationships, or calculation of gradient of graphs.
b summary of evidence	Note differences between situations/cases, or compare individual results.	Identify trends or general correlations in the data	Describe formal or statistical relationships within the cases/situations studied	Review the extent of, or limitations to, formal conclusions in relation to the scatter evident in the data.
c explanations suggested	Link the outcomes to previous experience or ‘common sense’.	Relate the conclusion to scientific ideas/explanations.	Justify the conclusion by reference to relevant scientific knowledge and understanding.	Use detailed scientific knowledge to explain all aspects of the given conclusion.

² ‘Patterns’ here means similarities, or differences, or the presence or absence of a relationship (e.g. a correlation between a factor and an outcome, or a trend linking two variables)

Strand E: Evaluation

Candidates are expected to be able to look back at the investigation they have carried out, showing what they have learned from doing it and explaining how they would modify it in the light of this, were they to carry it out again. These suggestions may demonstrate understanding of:

- difficulties in collecting valid and reliable data (IaS 1.1-2);
- weaknesses in the design of the data set collected, such as imperfect control of other variables, or the size and matching of samples compared (IaS 2.3, 2.6-7);
- assessing the level of confidence that can be placed in these conclusions (IaS 2.2-3, 2.7-8).

Aspect of Performance	Strand E Mark			
	2	4	6	8
a evaluation of procedures	Make a relevant comment about how the data was collected and about safety procedures.	Comment on the limitations to accuracy or range of data imposed by the techniques and equipment, used.	Suggest improvements to apparatus or techniques, or alternative ways to collect the data, but without sufficient practical detail.	Describe in detail improvements to the apparatus or techniques, or alternative ways to collect the data, and explain why they would be an improvement.
b reliability of evidence	Make a claim for accuracy or reliability, but without appropriate reference to the data.	Note the presence or absence of results that are beyond the range of experimental error.	Use the general pattern of results or degree of scatter between repeats as a basis for assessing accuracy and reliability.	Consider critically the reliability of the evidence, accounting for any anomalies.
c reliability of conclusion	Relate judgement of the reliability (or otherwise) of the conclusions only to techniques used, not to data collected.	Link confidence in the conclusion to the apparent reliability of the data collected	Discuss the precision of apparatus and techniques, the range covered and reliability of data to establish a level of confidence in the conclusions	Identify weaknesses in the data and give a detailed explanation of what further data would help to make the conclusions more secure.

Strand P: Presentation

The ability to report clearly and effectively on one's work is essential in order to demonstrate understanding of the Ideas-about-Science that relate to practical investigations.

Credit is awarded for three aspects of reporting and communicating a practical investigation:

- completeness of the report, with all practical procedures clearly described, all parameters and evidence reported, a full analysis of the evidence, and an evaluation of both procedures and evidence;
- presentation of the report, including layout and effective sequencing, use of illustrations as appropriate and use of graphs and charts to present information;
- correct use of English, including accurate grammar, punctuation and appropriate use of scientific terms.

Aspect of performance	Strand P Mark			
	2	4	6	8
a description of work planned and carried out	The purpose/context of the investigation is not made clear. Key features of experimental procedures are omitted or unclear.	The purpose of the work is stated. Main features of the work are described, but there is a lack of detail.	There is a clear statement of the question/task and its scope. Practical procedures are clearly described.	All aspects of the task are reviewed. Practical procedures are discussed critically and in detail.
b recording of data	Major experimental parameters are not recorded. Some data may be missing.	Most relevant data is recorded, but where repeats have been used, average values rather than raw data may be recorded.	All raw data, including repeat values, are recorded.	All relevant parameters and raw data including repeat values are recorded to an appropriate degree of accuracy.
	Labelling of tables is inadequate. Most units are absent or incorrect.	Labelling is unclear or incomplete. Some units may be absent or incorrect.	All quantities are identified, but some units may be omitted.	A substantial body of information is correctly recorded to an appropriate level of accuracy in well-organised ways.
	Observations are incomplete or sketchily recorded	Recording of observations is adequate but lacks detail.	Observations are adequate and clearly recorded.	Observations are thorough and recorded in full detail.
c general quality of communication	Spelling, punctuation and grammar are of generally poor quality. Little or no relevant technical or scientific vocabulary is used.	Use of appropriate vocabulary is limited. Spelling, punctuation and grammar are of very variable quality.	Appropriate scientific vocabulary is used. Spelling, punctuation and grammar are generally sound.	There is full and effective use of relevant scientific terminology. Spelling, punctuation and grammar are almost faultless.

5.3 Regulations for Internally Assessed Work

Supervision and Authentication of work

OCR expects teachers to supervise and guide candidates who are undertaking work that is internally assessed. The degree of teacher guidance will vary according to the kind of work being undertaken. It should be remembered, however, that candidates are required to reach their own judgements and conclusions.

When supervising internally assessed tasks, teachers are expected to:

- offer candidates advice about how best to approach such tasks;
- exercise supervision of work in order to monitor progress and to prevent plagiarism;
- ensure that the work is completed in accordance with the specification requirements and can be assessed in accordance with the specified mark descriptions and procedures.

Coursework should, wherever possible, be carried out under supervision. However, it is accepted that some tasks may require candidates to undertake work outside the Centre. Where this is the case, the Centre must ensure that sufficient supervised work takes place to allow the teachers concerned to authenticate each candidate's work with confidence.

Production and Presentation of internally assessed work

Candidates must observe certain procedures in the production of internally assessed work.

- Any copied material must be suitably acknowledged.
- Where work includes secondary data, the original sources must be clearly identified.
- Each candidate's assessed work submitted for moderation should be stapled together at the top left hand corner and have a completed cover sheet as the first page.

Annotation of Candidates' Work

Each piece of assessed work should be annotated to show how the marks have been awarded in relation to the mark descriptions.

The writing of comments on candidates' work provides a means of dialogue and feedback between teacher and candidate and a means of communication between teachers during internal standardisation of coursework.

However, the main purpose of annotating candidates' coursework is to provide a means of communication between teacher and moderator, showing where marks have been awarded and why they have been awarded.

Annotations should be made at appropriate points in the margins of the script of all work submitted for moderation. The annotations should indicate where achievement for a particular skill has been recognised.

It is suggested that the minimum which is necessary is that the 'shorthand' mark descriptions (for example, Ea8) should be written at the point on the script where it is judged that the work has met the mark description.

Moderation

All internally assessed work is marked by the teacher and internally standardised by the Centre. Marks are then submitted to OCR by a specified date, after which moderation takes place in accordance with OCR procedures. The purpose of moderation is to ensure that the standard of the award of marks is the same for each Centre and that each teacher has applied the standards appropriately across the range of candidates within the Centre.

It is the responsibility of the Centre to carry out effective internal standardisation to ensure that similar standards are applied by each teacher involved in the assessment. The Moderator will require a written statement describing how internal standardisation has been carried out within the Centre.

External moderation will be by postal sample selected by the Moderator.

The sample will represent performance across the whole ability range from the Centre. The sample of work which is presented to the Moderator for moderation must show how the marks have been awarded in relation to the mark descriptions.

Separate cover sheets are required for each candidate's work in the sample submitted for moderation.

Minimum Requirements for internally assessed work

If a candidate submits no work for this internally assessed unit, then the candidate should be indicated as being absent from that unit on the mark sheets submitted to OCR. If a candidate completes any work at all for an internally assessed unit, then the work should be assessed according to the criteria and mark descriptions and the appropriate mark awarded, which may be zero.

6 Technical Information

6.1 Making Unit Entries

Please note that centres must be registered with OCR in order to make any entries, including estimated entries. It is recommended that centres apply to OCR to become a registered centre well in advance of making their first entries. Centres should be aware that a minimum of ten candidates for summer examinations is normally required.

Unit Entry Options

Within Units A331, A332, and A333 candidates must be entered for either the Foundation Tier or the Higher Tier option. It is not necessary for candidates to enter at the same tier in every unit. Candidates may, if they wish, attempt papers at both tiers, but not in the same examination session, since the papers will be timetabled simultaneously.

Entry code	Option code	Component to be taken
A331	F	01 Physics A Unit 1 – modules P1, P2, P3 Foundation
	H	02 Physics A Unit 1 – modules P1, P2, P3 Higher
A332	F	01 Physics A Unit 2 – modules P4, P5, P6 Foundation
	H	02 Physics A Unit 2 – modules P4, P5, P6 Higher
A333	F	01 Physics A Unit 3 – Ideas in Context plus P7 Foundation
	H	02 Physics A Unit 3 – Ideas in Context plus P7 Higher
A339	–	01 Physics A Unit 4 – Practical Data Analysis and Case Study
A340	–	01 Physics A Unit 5 – Practical Investigation

Candidate entries must be made by 21 October for the January session and by 21 February for the June session.

6.2 Making Qualification Entries

Candidates must be entered for certification code **J635** to claim their overall GCSE grade.

If a certification entry is not made, no overall grade can be awarded.

A candidate who has completed all the units required for the qualification may enter for certification either in the same examination session (within a specified period after publication of results) or at a later session.

First certification will be available in June 2008 and every January and June thereafter.

Certification cannot be declined.

6.3 Grading

GCSE results are awarded on the scale A*-G. Units are awarded a* to g. Grades are awarded on certificates. Results for candidates who fail to achieve the minimum grade (G or g) will be recorded as unclassified (U or u).

In modular schemes candidates can take units across several different sessions. They can also re-sit units or choose from optional units available. When working out candidates' overall grades OCR needs to be able to compare performance on the same unit in different sessions when different grade boundaries have been set, and between different units. OCR uses uniform marks to enable this to be done.

A candidate's uniform mark is calculated from the candidate's raw mark. The raw grade boundary marks are converted to the equivalent uniform mark boundary. Marks between grade boundaries are converted on a pro rata basis.

When unit results are issued, the candidate's unit grade and uniform mark are given. The uniform mark is shown out of the maximum uniform mark for the unit e.g. 41/50.

Results for each unit will be published in the form of uniform marks according to the following scales.

	Unit Grade								
	a*	a	b	c	d	e	f	g	u
Units 1 and 2	50-45	44-40	39-35	34-30	29-25	24-20	19-15	14-10	10-0
Units 3, 4 and 5	100-90	89-80	79-70	69-60	59-50	49-50	39-30	29-20	19-0

Higher tier candidates may achieve an "allowed e". Higher tier candidates who miss a grade e will be given a uniform mark in the range f-u but will be graded as 'u'.

Candidates' uniform marks for each module are aggregated and grades for the specification are generated on the following scale.

Qualification Grade								
A*	A	B	C	D	E	F	G	U
300-270	269-240	239-210	209-180	179-150	149-120	119-90	89-60	59-0

The candidate's grade will be determined by this total mark. Thus, the grade awarded will depend in practice upon the extent to which the candidate has met the assessment objectives overall. Shortcomings in some aspects of the assessment may be balanced by better performance in others. Candidates achieving less than the minimum mark for grade G will be unclassified.

6.4 Result Enquiries and Appeals

Under certain circumstances, a centre may wish to query the grade available to one or more candidates or to submit an appeal against an outcome of such an enquiry. Enquiries about unit results must be made immediately following the series in which the relevant unit was taken.

For procedures relating to enquires on results and appeals, centres should consult the OCR Handbook for Centres and the document Enquiries about Results and Appeals – Information and Guidance for Centres produced by the Joint Council. Copies of the most recent editions of these papers can be obtained from OCR.

6.5 Shelf-Life of Units

Individual unit results, prior to certification of the qualification, have a shelf-life limited only by that of the qualification.

6.6 Unit and Qualification Re-sits

Prior to certification, candidates may re-sit any unit once only. *Centres should note that at the time of publication this rule is under review.*

For each unit the better score will be used towards the final overall grade.

Candidates may enter for the full qualifications an unlimited number of times.

6.7 Guided Learning Hours

GCSE Physics requires 120 guided learning hours in total.

6.8 Code of Practice/Subject Criteria/Common Criteria Requirements

These specifications comply in all respects with the revised GCSE, GCE, VCE, GNVQ and AEA Code of Practice 2005/6, the subject criteria for GCSE Physics and The Statutory Regulation of External Qualifications 2004.

6.9 Arrangements for Candidates with Particular Requirements

For candidates who are unable to complete the full assessment or whose performance may be adversely affected through no fault of their own, teachers should consult the Access Arrangements and Special Consideration Regulations and Guidance Relating to Candidates who are Eligible for

Adjustments in Examinations. In such cases advice should be sought from OCR as early as possible during the course.

6.10 Prohibited Qualifications and Classification Code

Every specification is assigned to a national classification code indicating the subject area to which it belongs.

Centres should be aware that candidates who enter for more than one GCSE qualification with the same classification code will have only one grade (the highest) counted for the purpose of the School and College Performance Tables.

The classification code for this specification is 1210.

7 Other Specification Issues

7.1 Overlap with other Qualifications

This specification has been developed alongside GCSE Science A and GCSE Additional Applied Science.

7.2 Progression from these Qualifications

GCSE qualifications are general qualifications which enable candidates to progress either directly to employment, or to proceed to further qualifications.

Many candidates who enter employment with one or more GCSEs would undertake training or further part-time study with the support of their employers.

Progression to further study from GCSE will depend upon the number and nature of the grades achieved. Broadly, candidates who are awarded mainly grades G to D at GCSE could either strengthen their base through further study of qualifications at Level 1 within the National Qualifications Framework or could proceed to Level 2. Candidates who are awarded mainly grades C to A* at GCSE would be well prepared to broaden their base through further study of qualifications at Level 2 or to proceed to appropriate qualifications at Level 3 within the National Qualifications Framework.

Candidates intending to proceed to qualifications in the physics at Advanced level (Level 3 in the National Qualifications Framework) should have completed either a course in GCSE Physics or both GCSE Science and GCSE Additional Science.

7.3 ICT

In order to move on to more advanced study of science, candidates need to be confident and effective users of ICT. This specification provides candidates with a wide range of appropriate opportunities to use ICT in order to further their study of science.

Opportunities for ICT include:

- using of videos clips to show provide the context for topics studied and to illustrate the practical importance of the scientific ideas;
- gathering information from the Internet and CD-ROMs;
- gathering data using sensors linked to data-loggers or directly to computers;
- using spreadsheets and other software to process data;
- using animations and simulations to visualise scientific ideas;
- using modelling software to explore theories;
- using software to present ideas and information on paper and on screen;

Particular opportunities for the use of ICT appear in the introductions to each of the modules.

7.4 Citizenship

Since September 2002, the National Curriculum for England at Key Stage 4 has included a mandatory programme of study for Citizenship.

Core science is designed as a science education for future citizens which not only covers aspects of the Citizenship programme of study but also extends beyond that programme by dealing with important aspects of science which all people encounter in their everyday lives.

Citizenship Programme of Study

Opportunities for Teaching the Issues during the Course

Section 1: Knowledge and understanding about becoming informed citizens

How the economy functions, including the role of business and financial services

P3 Need for large scale power generation and the factors underlying the choice of fuels.

P5 The basis for charging customers for electricity supplies.

The media's role in society, including the internet, in providing information and affecting opinion

P2: The role of the media in reporting issues such as the possible health risks associated with mobile phones.

The rights and responsibilities of consumers, employers and employees

P2: The precautionary principle and its implication.

P3: The rights and responsibilities of workers and patients exposed to ionising radiation.

Section 2 : Enquiry and communication

Researching a topical scientific issue by analysing information from different sources, including ICT-based sources, showing an awareness of the use and abuse of statistics

Coursework: Case Study of a topical science-related issue.

Contributing to group and class discussions

There will be opportunities for discussion in every module, e.g.

P1: Discussion of alternative explanations to account for the distribution of the continents on Earth.

7.5 Key Skills

These specifications provide opportunities for the development of the Key Skills of Communication, Application of Number, Information Technology, Working with Others, Improving Own Learning and Performance and Problem Solving at Levels 1 and/or 2. However, the extent to which this evidence fulfils the Key Skills criteria at these levels will be totally dependent on the style of teaching and learning adopted for each unit.

The following table indicates where opportunities may exist for at least some coverage of the various Key Skills criteria at Levels 1 and/or 2 for each unit.

Level	Communication	Application of Number	IT	Working with Others	Improving Own Learning and Performance	Problem Solving
1	✓	✓	✓	✓	✓	✓
2	✓	✓	✓	✓	✓	✓

7.6 Spiritual, Moral, Ethical, Social, Legislative, Economic and Cultural Issues

A number of the scientific ideas which feature in this specification have a significant cultural influence on how people think about themselves and their environment. Also in this specification, candidates gain more insight into the reliability and significance of scientific data.

Issue	Opportunities for Teaching the Issues during the Course
The commitment of scientists to publish their findings and subject their ideas to testing by others.	Practical investigation: reviewing the strategy and procedures.
The range of factors which have to be considered when weighing the costs and benefits of scientific activity.	P2: People's response to the risks associated with electromagnetic radiation. P3: Risks associated with contamination or irradiation by radioactive materials.
The ethical implications of selected scientific issues.	P3: Long and short term economic and environmental costs and benefits related to the use of various energy sources.
Scientific explanations which give insight into the local and global environment	P1, P7: Study of the life history of stars, the possible futures for the Universe, and the possibility of life in other parts of the Universe.

7.7 Sustainable Development, Health and Safety Considerations and European Developments

OCR has taken account of the 1988 Resolution of the Council of the European Community and the Report Environmental Responsibility: An Agenda for Further and Higher Education, 1993 in preparing this specification and associated specimen assessments.

Issue	Opportunities for Teaching the Issues during the Course
Environmental issues	
Air Pollution	P2: The enhanced greenhouse effect and global warming.
Natural disasters and how to predict them	P1: Volcanic eruptions and earthquakes
Energy resources	P3: The environmental advantages and disadvantages of different energy sources for generating electricity
Health and Safety issues	
Safe practice in the laboratory	Coursework investigation: designing a strategy
Health and disease	P3: The risk of cancer associated with exposure to radioactive decay
Living with radiation	P2: ALARA principle and how it applies to electromagnetic radiation
	P3: ALARA principle and hoe it applies to radioactive decay

OCR has taken account of the 1988 Resolution of the Council of the European Community in preparing this specification and associated specimen assessments. European examples should be used where appropriate in the delivery of the subject content.

Although this specification does not make specific reference to the European Dimension it may be drawn into the course of study in a number of ways. The table below provides some appropriate opportunities.

Issue	Opportunities for Teaching the Issues during the Course
The importance of the science-based industry to European economies	P3: Contrasting solutions to the provision of electricity supplies on a large scale P7: European-wide space research

7.8 Avoidance of Bias

OCR has taken great care in preparation of these specifications and assessment materials to avoid bias of any kind.

7.9 Language

These specifications and associated assessment materials are in English only.

7.10 Support and Resources

The University of York Science Education Group (UYSEG) and the Nuffield Curriculum Centre have produced resources specifically to support this specification. The resources will comprise:

- candidates' texts;
- candidates' work books;
- teacher guide with suggested schemes of work and candidate activity sheets (in customizable format);
- technician guide;
- ICT resources (for example, animations, video clips, models and simulations);
- assessment materials;
- a website for teachers and candidates.

The resources are published by Oxford University Press. Further information is available from:

Customer Services: Telephone: 01536 741068
Fax: 01536 454579
email: schools.orders@oup.com

Support is also available from the OCR GCSE science website www.gcse-science.com where centres should register their intention to offer this qualification. Registering on this site provides access to a teachers' forum and local support networks.

Appendix A: Grade Descriptions

Grade F

Candidates demonstrate a limited knowledge and understanding of science content and how science works. They use a limited range of the concepts, techniques and facts from the specification, and demonstrate basic communication and numerical skills, with some limited use of technical terms and techniques.

They show some awareness of how scientific information is collected and that science can explain many phenomena.

They use and apply their knowledge and understanding of simple principles and concepts in some specific contexts. With help they plan a scientific task, such as a practical procedure, testing an idea, answering a question, or solving a problem, using a limited range of information in an uncritical manner. They are aware that decisions have to be made about uses of science and technology and, in simple situations familiar to them, identify some of those responsible for the decisions. They describe some benefits and drawbacks of scientific developments with which they are familiar and issues related to these.

They follow simple instructions for carrying out a practical task and work safely as they do so.

Candidates identify simple patterns in data they gather from first-hand and secondary sources. They present evidence as simple tables, charts and graphs, and draw simple conclusions consistent with the evidence they have collected.

Grade C

Candidates demonstrate a good overall knowledge and understanding of science content and how science works, and of the concepts, techniques, and facts across most of the specification. They demonstrate knowledge of technical vocabulary and techniques, and use these appropriately. They demonstrate communication and numerical skills appropriate to most situations.

They demonstrate an awareness of how scientific evidence is collected and are aware that scientific knowledge and theories can be changed by new evidence.

Candidates use and apply scientific knowledge and understanding in some general situations. They use this knowledge, together with information from other sources, to help plan a scientific task, such as a practical procedure, testing an idea, answering a question, or solving a problem.

They describe how, and why, decisions about uses of science are made in some familiar contexts. They demonstrate good understanding of the benefits and risks of scientific advances, and identify ethical issues related to these.

They carry out practical tasks safely and competently, using equipment appropriately and making relevant observations, appropriate to the task. They use appropriate methods for collecting first-hand and secondary data, interpret the data appropriately, and undertake some evaluation of their methods.

Candidates present data in ways appropriate to the context. They draw conclusions consistent with the evidence they have collected and evaluate how strongly their evidence supports these conclusions.

Grade A

Candidates demonstrate a detailed knowledge and understanding of science content and how science works, encompassing the principal concepts, techniques, and facts across all areas of the specification. They use technical vocabulary and techniques with fluency, clearly demonstrating communication and numerical skills appropriate to a range of situations.

They demonstrate a good understanding of the relationships between data, evidence and scientific explanations and theories. They are aware of areas of uncertainty in scientific knowledge and explain how scientific theories can be changed by new evidence.

Candidates use and apply their knowledge and understanding in a range of tasks and situations. They use this knowledge, together with information from other sources, effectively in planning a scientific task, such as a practical procedure, testing an idea, answering a question, or solving a problem.

Candidates describe how, and why, decisions about uses of science are made in contexts familiar to them, and apply this knowledge to unfamiliar situations. They demonstrate good understanding of the benefits and risks of scientific advances, and identify ethical issues related to these.

They choose appropriate methods for collecting first-hand and secondary data, interpret and question data skilfully, and evaluate the methods they use. They carry out a range of practical tasks safely and skilfully, selecting and using equipment appropriately to make relevant and precise observations.

Candidates select a method of presenting data appropriate to the task. They draw and justify conclusions consistent with the evidence they have collected and suggest improvements to the methods used that would enable them to collect more valid and reliable evidence.

Appendix B: Requirements Relating to Mathematics

During the course of study for this specification, many opportunities will arise for quantitative work, including appropriate calculations. The mathematical requirements which form part of the specification are listed below. Items in the first table may be examined in written papers covering both Tiers. Items in the second table may be examined only in written papers covering the Higher Tier.

Both Tiers

add, subtract and divide whole numbers
recognise and use expressions in decimal form
make approximations and estimates to obtain reasonable answers
use simple formulae expressed in words
understand and use averages
read, interpret, and draw simple inferences from tables and statistical diagrams
find fractions or percentages of quantities
construct and interpret pie-charts
calculate with fractions, decimals, percentage or ratio
solve simple equations
substitute numbers in simple equations
interpret and use graphs
plot graphs from data provided, given the axes and scales
choose by simple inspection and then draw the best smooth curve through a set of points on a graph

Higher Tier only

recognise and use expressions in standard form
manipulate equations
select appropriate axes and scales for graph plotting
determine the intercept of a linear graph
understand and use inverse proportion
calculate the gradient of a graph

Appendix C: Physical Quantities and Units

It is expected that candidates will show an understanding of the physical quantities and corresponding SI units listed below and will be able to use them in quantitative work and calculations. Whenever they are required for such questions, units will be provided and, where necessary, explained.

Fundamental Physical Quantities	
Physical quantity	Unit(s)
length	metre (m); kilometre (km); centimetre (cm); millimetre (mm)
mass	kilogram (kg); gram (g); milligram (mg)
time	seconds (s); millisecond (ms) year (a); million years (Ma); billion years (Ga)
temperature	degree Celsius ($^{\circ}\text{C}$); kelvin (K)
current	ampere (A); milliampere (mA)

Derived Quantities and Units	
Physical quantity	Unit(s)
area	cm^2 ; m^2
volume	cm^3 ; dm^3 ; m^3 ; litre (l); millilitre (ml)
density	kg/m^3 ; g/cm^3
force	newton (N)
speed, velocity	m/s; km/h
energy	joule (J) ; kilojoule (kJ); megajoule (MJ)
power	watt (W); kilowatt (kW); megawatt (MW)
frequency	hertz (Hz); kilohertz (kHz)
gravitational field strength	N/kg
potential difference	volt (V)
resistance	ohm (Ω)
radioactivity	becquerel (Bq)
radiation dose	sievert (Sv)
Momentum	kg m/s

Appendix D: Health and Safety

In UK law, health and safety is the responsibility of the employer. For most centres entering candidates for GCSE examinations this is likely to be the Local Education Authority or the Governing Body. Teachers have a duty to co-operate with their employer on health and safety matters. Various regulations, but especially the COSHH Regulations 1996 and the Management of Health and Safety at Work Regulations 1992, require that before any activity involving a hazardous procedure or harmful microorganisms is carried out, or hazardous chemicals are used or made, the employer must provide a risk assessment.

A useful summary of the requirements for risk assessment in school or college science can be found in Chapter 4 of Safety in Science Education. For members, the CLEAPSS guide, Managing Risk Assessment in Science offers detailed advice.

Most education employers have adopted a range of nationally available publications as the basis for their Model Risk Assessments. Those commonly used include:

- Safety in Science Education, DfEE, 1996, HMSO, ISBN 0 11 270915 X
- Topics in Safety 3rd edition, 2001, ASE ISBN 0 86357 316 9
- Safeguards in the School Laboratory, 10th edition, 1996, ASE ISBN 0 86357 250 2
- Hazcards, 1995 with 2004 updates, CLEAPSS School Science Service*
- CLEAPSS Laboratory Handbook, 1997 with 2004 update, CLEAPSS School Science Service*
- CLEAPSS Shorter Handbook (CLEAPSS 2000) CLEAPSS School Science Service*
- Hazardous Chemicals, A manual for Science Education, (SSERC, 1997) ISBN 0 9531776 0 2

*Note that CLEAPSS publications are only available to members or associates.

Where an employer has adopted these or other publications as the basis of their model risk assessments, an individual Centre then has to review them, to see if there is a need to modify or adapt them in some way to suit the particular conditions of the establishment. Such adaptations might include a reduced scale of working, deciding that the fume cupboard provision was inadequate or the skills of the candidates were insufficient to attempt particular activities safely.

The significant findings of such risk assessment should then be recorded, for example on schemes of work, published teachers guides, work sheets, etc.

There is no specific legal requirement that detailed risk assessment forms should be completed, although a few employers require this.

When candidates are planning their own investigative work the teacher has a duty to check the plans before the practical work starts and to monitor the activity as it proceeds.

Appendix E: Explanation of Terms Used in Module Content

All the Ideas-about-Science are expressed in terms of what the candidates know, understand or can do, and are prefixed by 'Candidates should' which is followed by statement containing one or more 'command' words.

This appendix, which is not intended to be exhaustive or prescriptive, provides some guidance about the meanings of these command words.

It must be stressed that the meaning of a term depends on the context in which it is set, and consequently it is not possible to provide precise definitions of these words which can be rigidly applied in all circumstances. Nevertheless, it is hoped that this general guidance will be of use in helping to interpret both the specification content and the assessment of this content in written papers.

Command words associated with scientific knowledge and understanding (AO1)

Candidates are expected to remember the facts, concepts, laws and principles which they have been taught. Command words in this category include Learning Outcomes beginning:

recall...., ...state...; ...recognise...; ...name...; ...draw...; ...test for...; ...appreciate... ; describe...

The words used on examination papers in connection with the assessment of these Learning Outcomes may include:

Describe...; List...; Give...; Name...; Draw...; Write...; What?...; How?...; What is meant by..?

e.g. 'What is meant by the term 'catalyst' ?'

'Name parts A, B and C on the diagram.'

Command words associated with interpretation, evaluation, calculation and communication (AO2)

The command words include:

...relate...; ...interpret...; ...carry out ...; ...deduce...; ..explain...; ...evaluate...;
...predict...; ...use...; ...discuss...; ...construct...; ...suggest...; ...calculate...;
...demonstrate...;

The use of these words involves the ability to recall the appropriate material from the specification content and to apply this knowledge and understanding.

Questions in this category may include the command words listed above together with Why...? Complete... Work out... How would you know that...? Suggest...

e.g. 'Use the graph to calculate the concentration of the acid.'

'Explain why it is important for these materials to be recycled.'

'Suggest two reasons why some people are concerned about the use of these artificial flavours in foods.'

Appendix F: Ideas About Science

In order to deal sensibly with science as we encounter it in everyday life, it is important not only to understand some of the fundamental scientific explanations of the behaviour of the natural world, but also to know something about science itself, how scientific knowledge has been obtained, how reliable it therefore is, what its limitations are, and how far we can therefore rely on it – and also about the interface between scientific knowledge and the wider society.

The kind of understanding of science that we would wish pupils to have by the end of their school science education might be summarised as follows:

The aim of science is to find explanations for the behaviour of the natural world. A good explanation may allow us to predict what will happen in other situations, and perhaps to control and influence events.

There is no single ‘method of science’ that leads automatically to scientific knowledge. Scientists do, however, have characteristic ways of working. In particular, data, from observations and measurements, are of central importance.

One kind of explanation is to identify a correlation between a factor and an outcome. This factor may then be the cause, or one of the causes, of the outcome. In complex situations, a factor may not always lead to the outcome, but increases the chance (or the risk) of it happening. Other explanations involve putting forward a theory to account for the data. Scientific theories often propose an underlying model, which may involve objects (and their behaviour) that cannot be observed directly.

Devising and testing a scientific explanation is not a simple or straightforward process. First, we can never be completely sure of the data. An observation may be incorrect. A measurement can never be completely relied upon, because of the limitations of the measuring equipment or the person using it.

Second, explanations do not automatically ‘emerge’ from the data. Thinking up an explanation is a creative step. So, it is quite possible for different people to arrive at different explanations for the same data. And personal characteristics, preferences and loyalties can influence the decisions involved.

The scientific community has established procedures for testing and checking the findings and conclusions of individual scientists, and arriving at an agreed view. Scientists report their findings to other scientists at conferences and in special journals. Claims are not accepted until they have survived the critical scrutiny of the scientific community. In some areas of enquiry, it has proved possible to eliminate all the explanations we can think of but one – which then becomes the accepted explanation (for the time being).

Where possible scientists choose to study simple situations in order to gain understanding. But it can then be difficult to apply this understanding to complex, real-world situations. So there can be legitimate disagreements about how to explain such situations, even where there is no dispute about the basic science involved.

The application of scientific knowledge, in new technologies, materials and devices, greatly enhances our lives, but can also have unintended and undesirable side-effects. An application of science may have social, economic and political implications, and perhaps also ethical ones. Personal and social decisions require an understanding of the science involved, but also involve knowledge and values beyond science.

This is, of course, a simplified account of the nature of science, which omits many of the ideas and subtleties that a contemporary philosopher or sociologist of science might think important. It is intended as an overview of science in terms which might be accessible to 14-16 year old candidates, to provide a basic understanding upon which those who wish may later build more

sophisticated understandings. It is important to note that the language in which it is expressed may well not be that which one would use in talking to candidates of this age.

The following pages set out in more detail the key ideas that such an understanding of science might involve, and what candidates should be able to do to demonstrate their understanding.

1 Data and their limitations

Data are the starting point for scientific enquiry – and the means of testing scientific explanations. But data can never be trusted completely, and scientists need ways of evaluating how good their data are.

	Ideas about science	A candidate who understands this...
1.1	Data are crucial to science. Explanations are sought to account for known data, and data are collected to test proposed explanations.	uses data rather than opinion in justifying an explanation
1.2	We can never be sure that a measurement tells us the true value of the quantity being measured.	can suggest reasons why a measurement may be inaccurate
1.3	If we make several measurements of the same quantity, the results are likely to vary. This may be because we have to measure several individual examples (e.g. the height of cress seedlings after 1 week), or because the quantity we are measuring is varying (e.g. amount of ozone in city air, time for a vehicle to roll down a ramp), and/or because of the limitations of the measuring equipment or of our skill in using it (e.g. repeat measurements when timing an event).	can suggest reasons why several measurements of the same quantity may give different results when asked to evaluate data, makes reference to its reliability (i.e. is it repeatable?)
1.4	Usually the best estimate of the value of a quantity is the average (or mean) of several repeat measurements.	can calculate the mean of a set of repeated measurements from a set of repeated measurements of a quantity, uses the mean as the best estimate of the true value can explain why repeating measurements leads to a better estimate of the quantity
1.5	The spread of values in a set of repeated measurements give a rough estimate of the range within which the true value probably lies.	can make a sensible suggestion about the range within which the true value of a measured quantity probably lies can justify the claim that there is/is not a 'real difference' between two measurements of the same quantity
1.6	If a measurement lies well outside the range within which the others in a set of repeats lie, or is off a graph line on which the others lie, this is a sign that it may be incorrect.	can identify any outliers in a set of data, and give reasons for including or discarding them

2 Correlation and cause

Scientists look for patterns in data, as a means of identifying possible cause-effect links, and working towards explanations.

	Ideas about science	A candidate who understands this...
2.1	It is often useful to think about processes in terms of factors which may affect an outcome (or input variable(s) which may affect an outcome variable).	in a given context, can identify the outcome and the factors that may affect it in a given context, can suggest how an outcome might be affected when a factor is changed
2.2	To investigate the relationship between a factor and an outcome, it is important to control all the other factors which we think might affect the outcome (a so-called 'fair test').	can identify, in a plan for an investigation of the effect of a factor on an outcome, the fact that other factors are controlled as a positive feature, or the fact that they are not as a design flaw can explain why it is necessary to control all factors thought likely to affect the outcome other than the one being investigated
2.3	If an outcome occurs when a specific factor is present, but does not when it is absent, or if an outcome variable increases (or decreases) steadily as an input variable increases, we say that there is a correlation between the two.	can give an example from everyday life of a correlation between a factor and an outcome
2.4	A correlation between a factor and an outcome does not necessarily mean that one causes the other; both might, for example, be caused by some other factor.	uses the ideas of correlation and cause appropriately when discussing historical events or topical issues in science can explain why a correlation between a factor and an outcome does not necessarily mean that one causes the other, and give an example to illustrate this
2.5	In some situations, a factor increases the chance (or probability) of an outcome, but does not invariably lead to it, e.g. a diet containing high levels of saturated fat increases an individual's risk of heart disease, but may not lead to it. We also call this a correlation.	can suggest factors that might increase the chance of an outcome, but not invariably lead to it can explain that individual cases do not provide convincing evidence for or against a correlation
2.6	To investigate a claim that a factor increases the chance (or probability) of an outcome, we compare samples (e.g. groups of people) that are matched on as many other factors as possible, or are chosen randomly so that other factors are equally likely in both samples. The larger the samples the more confident we can be about any conclusions drawn.	can evaluate the design for a study to test whether or not a factor increases the chance of an outcome, by commenting on sample size and how well the samples are matched can use data to develop an argument that a factor does/does not increase the chance of an outcome
2.7	Even when there is evidence that a factor is correlated with an outcome, scientists are unlikely to accept that it is a cause of the outcome, unless they can think of a plausible mechanism linking the two.	can identify the presence (or absence) of a plausible mechanism as significant for the acceptance (or rejection) of a claimed causal link

3 Developing explanations

Scientific explanations are of different types. Some are based on a proposed cause-effect link. Others show how a given event is in line with a general law, or with a general theory. Some theories involve a model, which may include objects or quantities that cannot be directly observed, which accounts for the things we can observe.

	Ideas about science	A candidate who understands this...
3.1	A scientific explanation is a conjecture (a hypothesis) about how data might be accounted for. It is not simply a summary of the data, but is distinct from it.	can identify statements which are data and statements which are (all or part of) an explanation can recognise data or observations that are accounted for by, or conflict with, an explanation
3.2	An explanation cannot simply be deduced from data, but has to be thought up imaginatively to account for the data.	can identify imagination and creativity in the development of an explanation
3.3	A scientific explanation should account for most (ideally all) of the data already known. It may explain a wide range of observations. It should also enable predictions to be made about new situations or examples.	can justify accepting or rejecting a proposed explanation on the grounds that it: <ul style="list-style-type: none">• accounts for observations and/or provides an explanation that links things previously thought to be unrelated and/or leads to predictions that are subsequently confirmed
3.4	Scientific explanations are tested by comparing predictions made from them with data from observations or experiments.	can draw valid conclusions about the implications of given data for a given explanation, in particular: <ul style="list-style-type: none">• recognises that an observation that agrees with a prediction (derived from an explanation) increases confidence in the explanation but does not prove it is correct• recognises that an observation that disagrees with a prediction (derived from an explanation) indicates that either the observation or the prediction is wrong, and that this may decrease our confidence in the explanation.
3.5	For some questions that scientists are interested in, there is not yet an answer.	can identify a scientific question for which there is not yet an answer, and suggest a reason why.

4 The scientific community

Findings reported by an individual scientist or group are carefully checked by the scientific community before being accepted as scientific knowledge.

	Ideas about science	A candidate who understands this...
4.1	Scientists report their findings to other scientists through conferences and journals. Scientific findings are only accepted once they have been evaluated critically by other scientists.	can describe in broad outline the 'peer review' process, in which new scientific claims are evaluated by other scientists can recognise that new scientific claims which have not yet been evaluated by the scientific community are less reliable than well-established ones
4.2	Scientists are usually sceptical about findings that cannot be repeated by anyone else, and about unexpected findings until they have been replicated.	can identify absence of replication as a reason for questioning a scientific claim can explain why scientists regard it as important that a scientific claim can be replicated by other scientists
4.3	Explanations cannot simply be deduced from the available data, so two (or more) scientists may legitimately draw different conclusions about the same data. A scientist's personal background, experience or interests may influence his/her judgments. (e.g. data open to several interpretations; influence of personal background and experience; interests of employers or sponsors).	can suggest plausible reasons why scientists involved in a scientific event or issue disagree(d)
4.4	A scientific explanation is rarely abandoned just because some data are not in line with it. An explanation usually survives until a better one is proposed. (e.g. anomalous data may be incorrect; new explanation may soon run into problems; safer to stick with ideas that have served well in the past).	can suggest reasons for scientists' reluctance to give up an accepted explanation when new data appear to conflict with it

5 Risk

Every activity involves some risk. Assessing and comparing the risks of an activity, and relating these to the benefits we gain from it, are important in decision making.

	Ideas about science	A candidate who understands this...
5.1	Everything we do carries a certain risk of accident or harm. Nothing is risk free. New technologies and processes based on scientific advances often introduce new risks.	<p>can explain why it is impossible for anything to be completely safe</p> <p>can identify examples of risks which arise from a new scientific or technological advances</p> <p>can suggest ways of reducing specific risks</p>
5.2	We can sometimes assess the size of a risk by measuring its chance of occurring in a large sample, over a given period of time.	can interpret and discuss information on the size of risks, presented in different ways.
5.3	To make a decision about a particular risk, we need to take account both of the chance of it happening and the consequences if it did.	can discuss a given risk, taking account of both the chance of it occurring and the consequences if it did.
5.4	People are often willing to accept the risk associated with an activity if they enjoy or benefit from it. We are also more willing to accept the risk associated with things we choose to do than things that are imposed, or that have short-lived effects rather than a long-lasting ones.	<p>can suggest benefits of activities that have a known risk</p> <p>can offer reasons for people's willingness (or reluctance) to accept the risk of a given activity</p> <p>can discuss personal and social choices in terms of a balance of risk and benefit</p>
5.5	If you are not sure about the possible results of doing something, and if serious and irreversible harm could result from it, then it makes sense to avoid it (the 'precautionary principle').	can identify, or propose, an argument based on the 'precautionary principle'
5.6	Our perception of the size of a risk is often very different from the actual measured risk. We tend to over-estimate the risk of unfamiliar things (like flying as compared with cycling), and things whose effect is invisible (like ionizing radiation).	<p>can distinguish between actual and perceived risk, when discussing personal and social choices</p> <p>can suggest reasons for given examples of differences between actual and perceived risk</p>
5.7	Reducing the risk of a given hazard costs more and more, the lower we want to make the risk. As risk cannot be reduced to zero, individuals and/or governments have to decide what level of risk is acceptable.	can explain what the ALARA (as low as reasonably achievable) principle means and how it applies in a given context

6 Making decisions about science and technology

To make sound decisions about the applications of scientific knowledge, we have to weigh up the benefits and costs of new processes and devices. Sometimes these decisions also raise ethical issues. Society has developed ways of managing these issues, though new developments can pose new challenges to these.

	Ideas about science	A candidate who understands this...
6.1	Science-based technology provides people with many things that they value, and which enhance the quality of life. Some applications of science can, however, have unintended and undesirable impacts on the quality of life or the environment. Benefits need to be weighed against costs.	in a particular context, can identify the groups affected and the main benefits and costs of a course of action for each group
6.2	Scientists may identify unintended impacts of human activity (including population growth) on the environment. They can sometimes help us to devise ways of mitigating this impact and of using natural resources in a more sustainable way.	can explain the idea of sustainable development, and apply it to specific situations
6.3	In many areas of scientific work, the development and application of scientific knowledge are subject to official regulations and laws (e.g. on the use of animals in research, levels of emissions into the environment, research on human fertility and embryology).	shows awareness that scientific research and applications are subject to official regulations and laws.
6.4	Some questions, such as those involving values, cannot be addressed by scientists.	can distinguish questions which could be addressed using a scientific approach, from questions which could not
6.5	Some applications of science have ethical implications. As a result, people may disagree about what should be done (or permitted).	where an ethical issue is involved, can: <ul style="list-style-type: none"> • say clearly what this issue is • summarise different views that may be held
6.6	In discussions of ethical issues, one common argument is that the right decision is one which leads to the best outcome for the majority of people involved. Another is that certain actions are unnatural or wrong, and should not be done in any circumstances. A third is that it is unfair for a person to choose to benefit from something made possible only because others take a risk, whilst avoiding that risk themselves.	in a particular context, can identify, and develop, arguments based on the ideas that: <ul style="list-style-type: none"> • the right decision is the one which leads to the best outcome for the majority of people involved • certain actions are never justified because they are unnatural or wrong
6.7	In assessing any proposed application of science, we must first decide if it is technically feasible. Different decisions on the same issue may be made in different social and economic contexts.	in a particular context, can distinguish what can be done (technical feasibility), from what should be done (values) can explain why different courses of action may be taken in different social and economic contexts.

Appendix G: Science Explanations

Material in italics is from earlier Key Stages. This material will not be the focus of assessment items but clearly there will be instances where an understanding of material from earlier stages will underpin an understanding of Key Stage 4 material. Material in bold is only intended for Higher Tier candidates.

This section lists the Science Explanation relevant to this specification. Other ideas about Science are listed in GCSE Biology A and GCSE Physics A specifications. The full set of Science Explanations are included in the GCSE Science A specification.

SE 11 Energy sources and use

- a *We often need a source of energy to change things in some way or make things happen. Fuels (e.g. coal, oil, natural gas and wood) are very valuable because, when oxygen is also available, they are very concentrated sources of energy. There is, however, only a limited amount of fossil fuels (coal, oil and natural gas) in the Earth's crust so they are a non-renewable energy source. Wood, from trees, is a renewable fuel when properly managed.*
-
- b In some situations, we can use less concentrated renewable energy sources (for example, wind, waves, tides, dammed rainwater or radiation from the Sun) instead of fuels. Radioactive elements such as uranium release energy as they decay. This can heat up rocks in the Earth's crust (geothermal energy). We can also make uranium atoms release a lot of energy by splitting them in nuclear reactors (nuclear fission).
-
- c *Moving objects have (kinetic) energy; (potential) energy can be stored in objects that are lifted up against the force of gravity and in elastic objects that have been stretched, compressed, bent or twisted; a hot object has more (thermal) energy than the same object when it is cooler.*
-
- d Energy can be transferred from one object to another in various ways:
mechanically (by one object pushing or pulling another);
thermally (by conduction or convection of energy from a high temperature region to a low temperature region);
electrically (by an electric current);
by radiation.
-
- e Electricity is very convenient because it can readily be transferred from where it is generated to where it is needed, and can then readily be used to produce movement (kinetic) energy, light, sound or heating as required. Electricity is, however, a secondary energy source; another (primary) energy source is needed to generate it. In most power stations this is done by using a fuel (fossil or nuclear) to boil water and then using the steam to turn a turbine, which rotates a generator to generate electricity.
-

SE 12 Radiation

a Some processes in which one object affects another some distance away fit the following general model:

radiation
source → receiver

One object (a source) emits radiation (of some kind). This travels from the source and can affect another object (a receiver) some distance away. When radiation strikes an object, some may pass through it, or be reflected or absorbed. A detector of radiation is simply an absorber which produces some observable response to the radiation it has absorbed. When radiation is absorbed it ceases to exist as radiation; usually it simply heats the absorber.

b Light is one of a family of radiations. The spectrum of visible light (red→violet) can be extended in both directions:

radio microwave infrared red light violet ultraviolet X-ray gamma

The whole family of radiations is called the electromagnetic spectrum.

c Some types of electromagnetic radiation when absorbed do not just cause heating; X-rays, gamma rays and ultraviolet radiation can cause damage to the molecules in living cells. Radiation that can do this is called ionising radiation. When ionising radiation strikes molecules it can make them more likely to react chemically. Exposure to large amounts of ionising radiation can kill living cells; smaller amounts may cause changes to cells which can make them grow in an uncontrolled way, causing cancer.

SE 13 Radioactivity

a Some elements emit bursts of radiation all the time. even if they are broken into very small pieces, dissolved or chemically reacted to form new chemicals. Such elements or compounds containing such elements are called radioactive materials.

b There are three types of radiation emitted by radioactive materials:

alpha (α) radiation which is easily absorbed, for example by a thin layer of paper or a few centimetres of air;

beta (β) radiation which passes fairly easily through many substances but can be absorbed by a thin sheet of any metal;

gamma (γ) radiation which passes very easily through most substances (it is penetrating) and needs a thick sheet of a dense metal such as lead, or concrete several metres thick, to absorb most of it.

c Most types of atom never change; they are stable. But radioactive materials contain unstable atoms. The nucleus of an unstable atom can break up (decay) and when this happens it emits radiation. An atom of a different atom is left behind. As time goes by radioactive materials contain fewer and fewer unstable atoms and so become less and less radioactive and emit less and less radiation. The time it takes for a radioactive material to become half as radioactive as it was to begin with (because half of the unstable atoms that were originally there have decayed) is called the half-life. Some radioactive materials have half-lives of billions of years; others have half-lives of a fraction of a second.

d All three types of radiation from radioactive materials are ionising radiations. When such radiation strikes living cells, these may be killed or become cancerous (i.e. grow in an uncontrolled way). Ionising radiation can be used to kill harmful cells and is used in this way to treat cancer and to sterilise surgical instruments. For each millimetre that it travels through a living cell, alpha radiation is most likely to cause damage and gamma radiation is the least likely to cause damage. The risk of cancer from radiation damage increases steadily with the amount of radiation that a person is exposed to.

e Radioactive materials can affect living cells in two different ways:
the radiation from a radioactive material can reach a person (or other organism). This is irradiation;
bits of the radioactive material can get into, or on to the person, or their clothes. This is contamination.
We are irradiated and contaminated all the time because of radioactive materials in the air, in building materials, in the soil and in our food. Medical treatments, and occupational or medical exposure to radioactive materials, increase the dose that some individuals receive. The dose received by people who are regularly exposed to radiation is carefully monitored.

f Some unstable atoms, for example atoms of uranium and plutonium, can be made to split into two roughly equal parts. This is called nuclear fission. The amount of energy released is much larger, per atom, than in a chemical reaction. Nuclear fission, at a very carefully limited rate, is used in nuclear power stations. Nuclear fission that is allowed to occur at a rapidly accelerating rate leads to a massive explosion; this is how nuclear weapons work.

SE 14 The Earth

- a The Earth is a sphere with a radius of about 6 400 kilometres. It consists of several layers: on the outside, where we live, is a relatively thin crust made from solid rocks; below the crust, there is a thick layer of rock called the mantle which goes down about halfway to the centre of the Earth.
- The rock which makes up the mantle is very hot but under pressure. It melts when the pressure is reduced. The molten rock (magma) formed in this way rises and cause volcanic eruptions.
- Some changes in the Earth's surface are very slow and take place over a very long time. The mountains of the Earth's crust are gradually eroded so that the Earth's surface would be worn down to sea level if parts of the Earth's crust were not being uplifted to form new mountains.
- Early in the 20th century, Wegener suggested that mountains might be formed as slowly drifting continents collided with each other. He suggested that the jigsaw fit of the east coast of South America and the west coast of Africa, together with the matching patterns of rocks and fossils, were evidence of continental drift. Most geologists at the time rejected this theory.
- By the mid-20th century geologists:
- knew that the mantle, even when solid, can flow very slowly;
 - knew that the inside of the Earth is kept hot by the energy released when the atoms of radioactive elements inside the Earth decay;
 - had discovered [mid-]oceanic ridges **and evidence that these were caused by sea-floor spreading.**

- b The theory of plate tectonics is the unifying theory of Earth Science, explaining many rock cycle processes and changes to the Earth's surface. According to this theory, the outer rigid layer of the Earth consists of a number of separate pieces called tectonic plates. These are constantly, but extremely slowly, moving. Movement of the mantle, caused by heating from radioactive decay, contributes to the movement of the plates. At mid-ocean ridges, where plates are moving apart, molten rock (magma) rises up between the plates. In some places the plates are moving towards each other. This produces tremendous pressures that can deform rocks into mountain chains. The colliding plates may also cause earthquakes and volcanoes. An earthquake occurs when two blocks of rock, that are held together by friction, move suddenly because of the forces acting on them. Earthquakes occur where the edges of plates slide past each other, where plates collide and the more dense oceanic plate sinks beneath a less dense continental plate, and where faulting occurs near the mid-ocean ridges

- c The Earth is surrounded by a thin layer of atmosphere which allows light radiated from the Sun to pass through. This radiation provides the energy for plants to make glucose using carbon dioxide and water by the process of photosynthesis. Radiation from the Sun is absorbed by the Earth's surface, making it warmer. Different infrared radiation is then emitted by the Earth and absorbed by the atmosphere so keeping the Earth warmer than it would otherwise be. This is called the greenhouse effect. The temperature on the Earth's surface is often high enough for water to be liquid.
- The atmosphere also contains oxygen (a waste product of photosynthesis). This is needed by animals for respiration. **Oxygen is acted on by radiation to produce ozone in the upper atmosphere. This absorbs ultraviolet radiation, and protects living organisms, especially animals, from its harmful effects.**







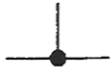

SE 15 The Solar System

- a *The Earth is a planet that moves round the Sun. It takes one year to make a complete orbit. Other planets also move around the Sun. The Sun, the planets and other smaller bodies such as satellites (moons) of planets, asteroids and comets make up the Solar System.*
- b The Sun is a star. It was formed, **about 5000 million years ago**, in the same way as other stars by clouds of gas, being drawn together by the force of gravity. In stars, hydrogen **nuclei join (fuse)** and energy is released. The Sun will continue to shine for another 5000 million years. It will then become red giant, engulfing or evaporating the Earth, and finally, a very dense black dwarf.

SE 16 The Universe

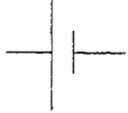
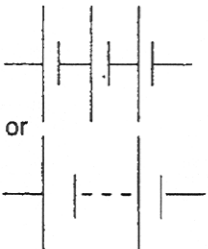
- a The Sun is just one of billions of stars which are clustered in a group called the Milky Way galaxy. The diameter of the galaxy is 100 000 light years. The Universe is made up of billions of galaxies, many times their own diameter apart, so it is vast.
-
- b Distant galaxies are moving away from us. This means that the Universe is getting bigger (expanding). The more distant a galaxy is, the faster it is moving away. This suggests that the Universe might have begun in one place with a huge explosion (the 'big bang') about 13700 million years ago.
-
- c We do not know whether the Universe will keep on expanding for ever or whether the force of gravity between the galaxies will slow them down enough to stop them moving apart so they will then start moving together again. Eventually there would then be a 'big crunch'.
-
- d There are billions of galaxies, each containing billions of stars. Astronomers have detected planets around some nearby stars. If even a small proportion of stars have planets, many scientists think that it is very likely that life, and perhaps even intelligent life, exists elsewhere in the Universe.
-

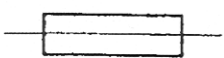
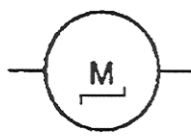
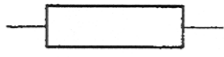
Appendix H: Electrical Symbols

junction of conductors		ammeter	
switch		voltmeter	
primary or secondary cell			
battery of cells	or 	indicator or light source	
power supply			
fuse		motor	
fixed resistor		generator	
variable resistor	