

OXFORD CAMBRIDGE AND RSA EXAMINATIONS

Advanced Subsidiary GCE

PHYSICS B (ADVANCING PHYSICS)

2861

Understanding Processes

Thursday **12 JANUARY 2006** Morning 1 hour 30 minutes

Candidates answer on the question paper.

Additional materials:

- Data, Formulae and Relationships Booklet
- Electronic calculator
- Protractor
- Ruler

Candidate Name	Centre Number	Candidate Number									
	<table border="1" style="display: inline-table; border-collapse: collapse;"> <tr> <td style="width: 20px; height: 20px;"></td> <td style="width: 20px; height: 20px;"></td> <td style="width: 20px; height: 20px;"></td> <td style="width: 20px; height: 20px;"></td> <td style="width: 20px; height: 20px;"></td> </tr> </table>						<table border="1" style="display: inline-table; border-collapse: collapse;"> <tr> <td style="width: 20px; height: 20px;"></td> <td style="width: 20px; height: 20px;"></td> <td style="width: 20px; height: 20px;"></td> <td style="width: 20px; height: 20px;"></td> </tr> </table>				

TIME 1 hour 30 minutes

INSTRUCTIONS TO CANDIDATES

- Write your name in the space above.
- Write your Centre number and Candidate number in the boxes above.
- Answer **all** the questions.
- Write your answers in the spaces provided on the question paper.
- Read each question carefully and make sure you know what you have to do before starting your answer.
- Show clearly the working in all calculations and give answers to only a justifiable number of significant figures.

INFORMATION FOR CANDIDATES

- You are advised to spend about 20 minutes on Section A, 40 minutes on Section B and 30 minutes on Section C.
- The number of marks is given in brackets [] at the end of each question or part question.
- There are four marks for the quality of written communication in Section C.
- The values of standard physical constants are given in the Data, Formulae and Relationships Booklet. Any additional data required are given in the appropriate question.

FOR EXAMINER'S USE		
Section	Max.	Mark
A	20	
B	40	
C	30	
TOTAL	90	

This question paper consists of 21 printed pages and 3 blank pages.

Answer **all** the questions.

Section A

1

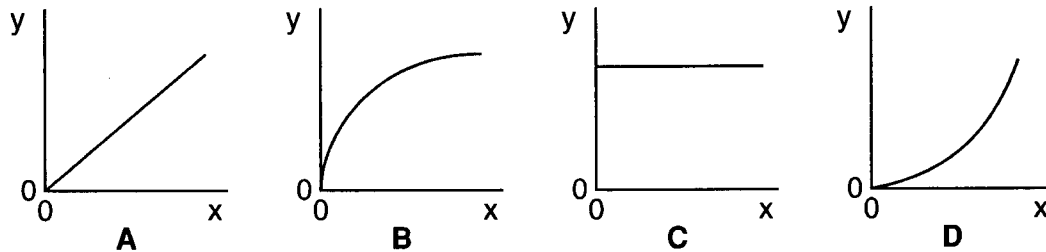

Fig. 1.1

Which graph, **A**, **B**, **C** or **D**, in Fig. 1.1 is obtained when the y and x axes represent the two quantities given in each case below?

(a) y -axis: the **distance** moved from rest by a car travelling at constant acceleration

x -axis: **time**

answer

(b) y -axis: the vertical **velocity** of a skydiver falling from rest under the combined effects of gravity and air resistance

x -axis: **distance** fallen

answer

(c) y -axis: the **velocity** of an electromagnetic wave in space

x -axis: the **frequency** of the wave

answer

[3]

- 2 An ultrasonic 'tape measure' is used to measure the distance across a room.

The tape measure sends out pulses of ultrasound towards the distant wall and electronically measures the time for the pulse to return. In a particular measurement, the pulse returns after 20 ms.

Calculate the distance across the room.

speed of ultrasound in air = 340 m s^{-1}

distance = m [3]

- 3 When **white** light reflects from a thin film of oil on the surface of a puddle of water, different colours can be seen across the film.

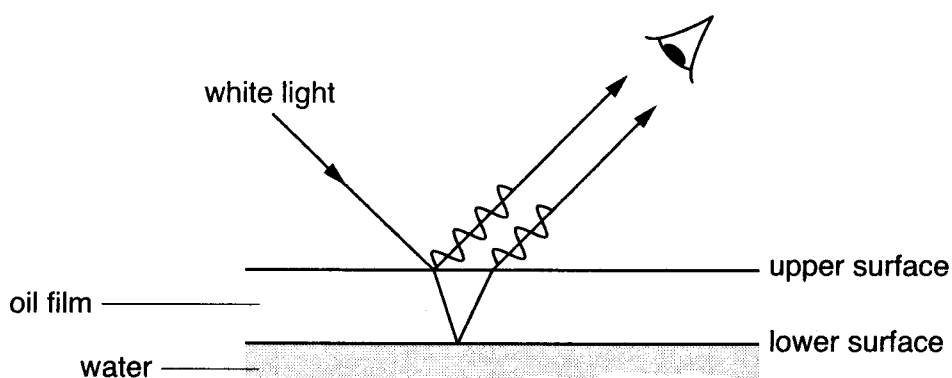

Fig. 3.1

Two paths of light partially reflected from the oil film are shown in Fig. 3.1.

When looking in **this** direction the colour of the film is lacking in red, and so appears **blue-green** in colour.

By considering light travelling along the two paths, explain why this is so.

[3]

[Turn over

- 4 A motor boat heads directly across a wide river towards the opposite bank. Its speed in still water is 2.0 m s^{-1} .

The river is flowing at 1.5 m s^{-1} , as shown in Fig. 4.1.

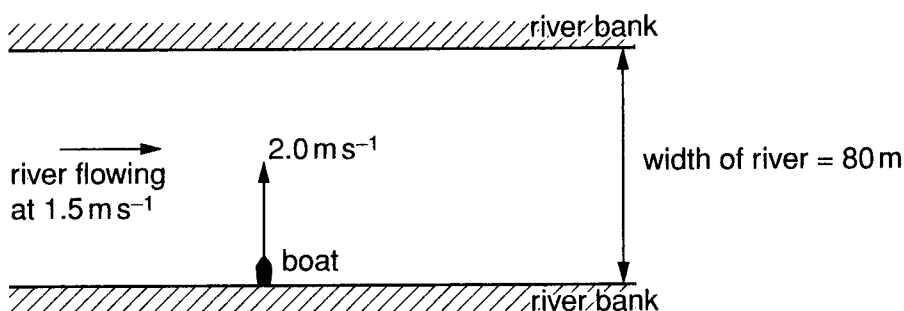

Fig. 4.1

The resultant velocity of the boat is found to be 2.5 m s^{-1} at an angle of 53° to the direction of flow of the river.

- (a) By scale drawing, or some other method of your choosing, show how the resultant velocity is found.

[2]

- (b) The river is 80 m wide and the boat crosses to the other side in 40 s.

Explain why the speed of flow of the river does **not** affect the time for the boat to cross the river in this case.

[2]

- 5 Photons travel from a distant monochromatic light source to distant detectors **X** and **Y** through three equally spaced narrow slits, as shown in Fig. 5.1.

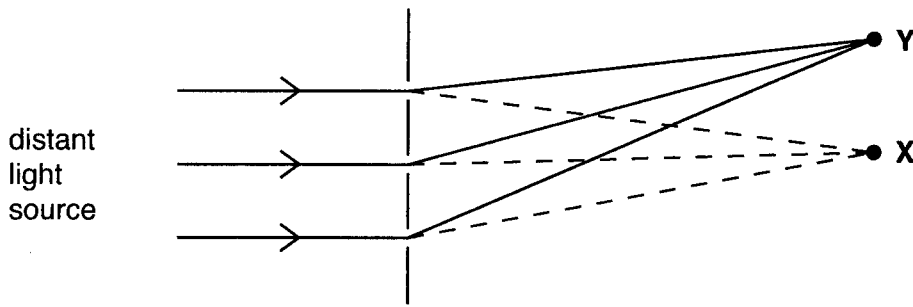
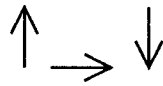

Fig. 5.1

- (a) At **Y**, the three phasors associated with the paths from the three slits are



Combine the phasors to show the **resultant** phasor amplitude for these three paths.

[1]

- (b) At **X**, the intensity is **maximum**.

Calculate the value of the ratio $R = \frac{\text{intensity at X}}{\text{intensity at Y}}$.

$R = \dots\dots\dots$ [2]

6

6

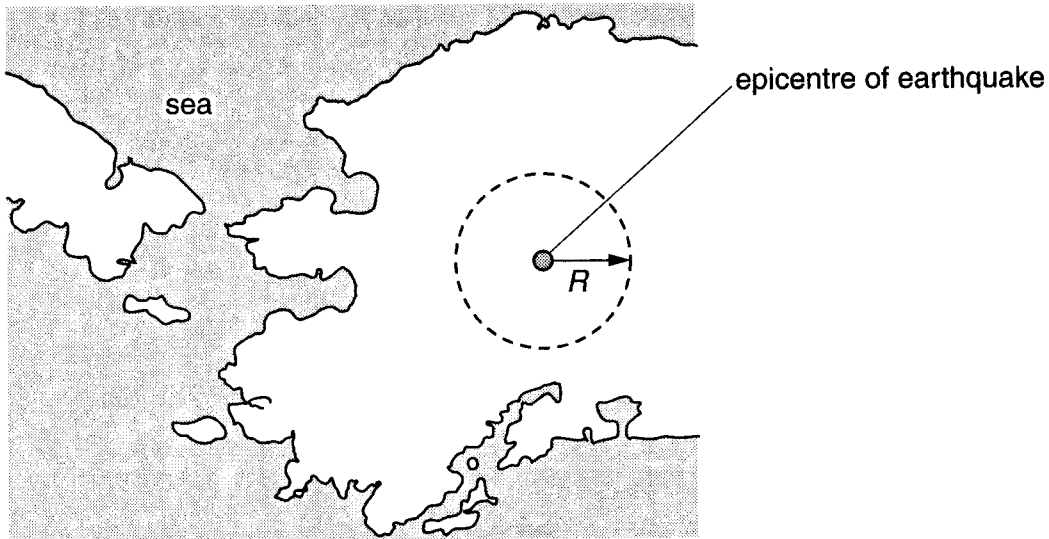

Fig. 6.1

Earthquakes begin with vibrations at a source below the Earth's surface. The point on the Earth's surface immediately above the source is called the epicentre.

Some vibrations travel along the surface away from the epicentre, decreasing in intensity. At some distance R from the epicentre, the ground movement becomes too weak to be felt and beyond this distance there is little or no structural damage to buildings (Fig. 6.1).

- (a) The distance R is found to increase with M , the magnitude of the earthquake. It is suggested that the relationship between R and M is given by the expression

$$R = qM^3 \quad \text{where } q \text{ is a constant.}$$

The table shows some data.

R / km	M
58	4.0
112	5.0
198	6.0

Propose and carry out a test to see whether the data fit the relationship.

test proposed

test carried out

[2]

- (b) State your conclusion.

[1]

- 7 Ocean waves of long wavelength λ travel in deep water at a speed v given by

$$v = \sqrt{\frac{g\lambda}{2\pi}} \text{ where } g \text{ is the gravitational field strength.}$$

Here is a list of four graphs that could be plotted relating v to λ .

- A** v against λ **B** v against λ^2 **C** v^2 against λ **D** v^2 against λ^2

Write down the letter (**A**, **B**, **C** or **D**) of the graph you would plot in order to obtain a straight line through the origin.

answer [1]

[Section A Total: 20]

Section B

8 This question is about using a diffraction grating to observe emission spectra.

- (a) The light emitted from a mercury vapour lamp consists of a spectrum of a few well defined wavelengths. The wavelengths associated with the four brightest lines are as follows.

colour	wavelength / m
yellow	5.8×10^{-7}
green	5.5×10^{-7}
blue	4.4×10^{-7}
violet	4.1×10^{-7}

- (i) Use the equation $E = hf$ to show that the photon energy E associated with light of wavelength λ is given by

$$E = \frac{hc}{\lambda}$$

where h is the Planck constant and c the speed of light in vacuum.

[2]

- (ii) Calculate the photon energy associated with the green line of the mercury emission spectrum.

$$h = 6.6 \times 10^{-34} \text{ J s}$$

$$c = 3.0 \times 10^8 \text{ m s}^{-1}$$

energy = J [1]

- (b) A collimated beam of light from a mercury vapour lamp passes through a diffraction grating. The grating splits up the light into different wavelengths at different angles θ (Fig. 8.1).

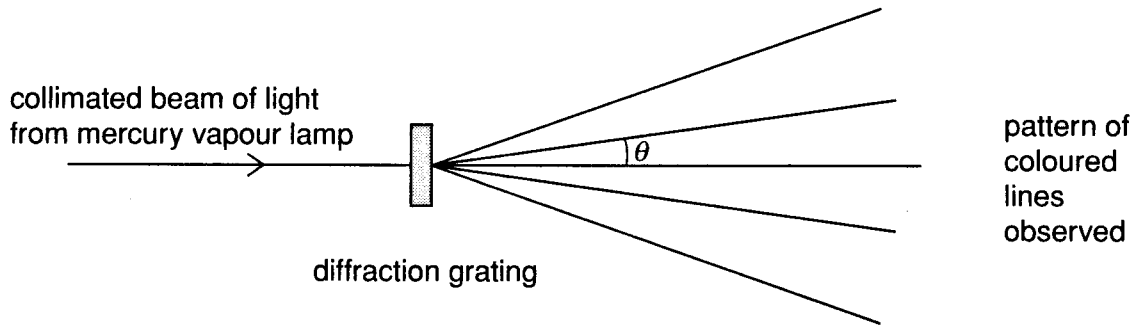

Fig. 8.1

The pattern of coloured lines observed is shown in Fig. 8.2.
The first order spectrum can be seen on either side of the central maximum.

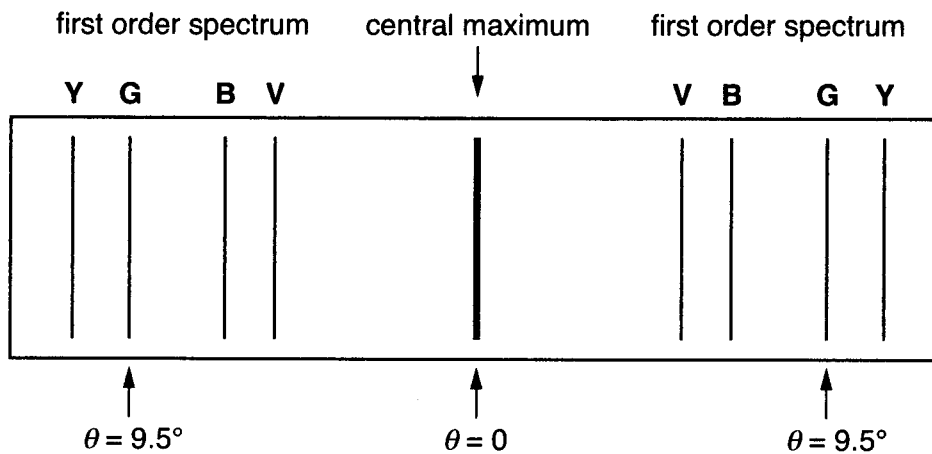

Fig. 8.2

- (i) Explain why the violet line V in the first order spectrum is produced at a smaller angle θ than the green line G.

[2]

Question continued on page 10

- (ii) The value of θ for the green line is found to be 9.5° . The wavelength of the green light is 5.5×10^{-7} m.

Calculate the spacing of the slits in the grating.

spacing = m [2]

- (iii) Hence calculate the number of lines **per mm** in this grating. Give your answer to an appropriate number of significant figures.

lines per mm = mm^{-1} [2]

- (iv) Justify the number of significant figures you have used in your answer.

[1]

[Total: 10]

BLANK PAGE

9 This question is about a large sea bird that “plunge-dives” to catch fish for food.

Gannets dive from a great height h above the sea to a remarkable depth (Fig. 9.1).

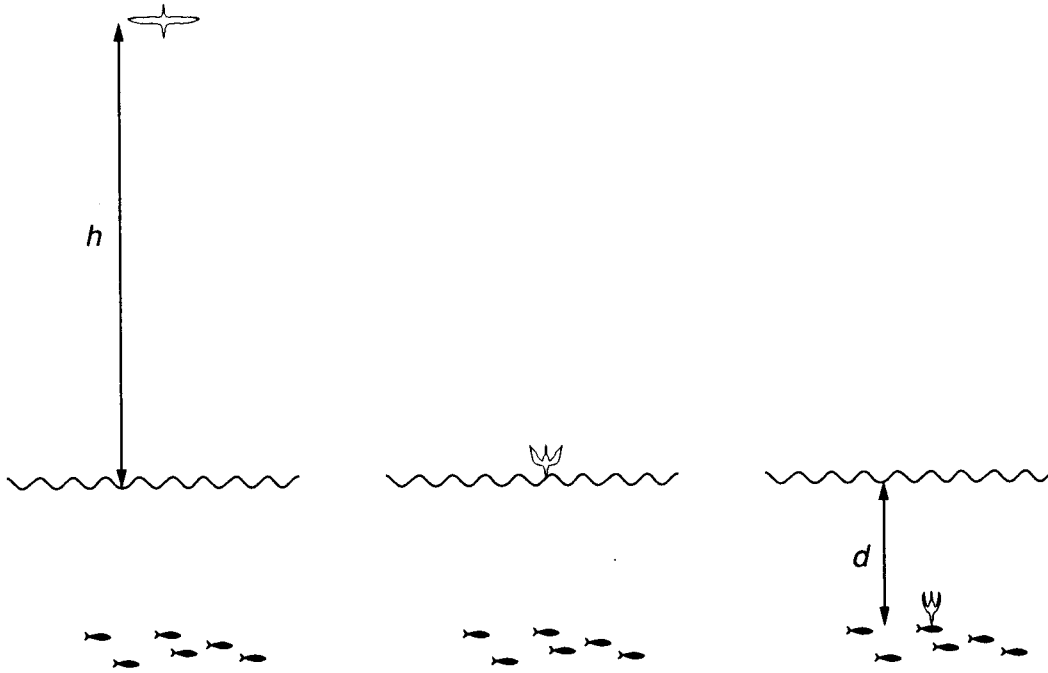

Fig. 9.1

- (a) Starting at height h above the surface of the sea, the gannet folds its wings so that it falls vertically under gravity with negligible air resistance.

Calculate its velocity at the surface after plunging from a height h of 30 m.

$$g = 9.8 \text{ m s}^{-2}$$

velocity = m s^{-1} [2]

- (b) (i) Show that the kinetic energy E of the gannet of mass 3.0 kg as it enters the water is 880 J.

[1]

- (ii) State where this kinetic energy comes from.

[1]

(c) After entering the water, there is a resultant upward force F on the gannet which brings it to rest in a distance d .

(i) Show that if the force F is assumed to be constant, $F = \frac{E}{d}$.

Explain your reasoning.

[2]

(ii) Show that for $d = 10$ m, the force F is about **three times** the body weight of the gannet.

[2]

(iii) State where the kinetic energy E has gone when the gannet has come to rest.

[1]

(d) (i) Suggest **one** reason why there is an upward force on the gannet as it dives through the water.

[1]

(ii) Suggest **one** reason why the resultant upward force will **not** be constant while the gannet is coming to rest.

[1]

[Total: 11]

[Turn over

- 10 This question is about the formation of standing waves in a microwave oven.

Marshmallow sweets can be served melted. An attempt to melt a plate of marshmallows is made in a microwave oven from which **the turntable has been removed** (Fig. 10.1).

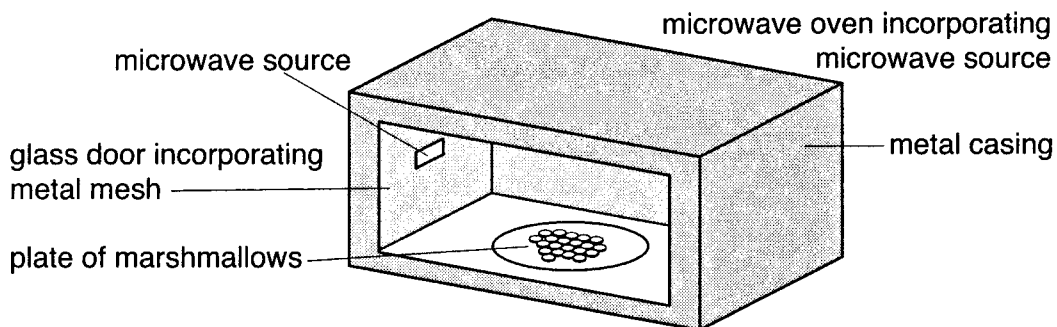

Fig. 10.1

- (a) Calculate the wavelength of the microwaves.

frequency of the microwaves = 2.5 GHz
 speed of microwaves = $3.0 \times 10^8 \text{ m s}^{-1}$

wavelength = m [3]

- (b) The marshmallows do not melt uniformly. The melting is concentrated at regularly spaced spots about 60 mm apart as shown in Fig. 10.2.

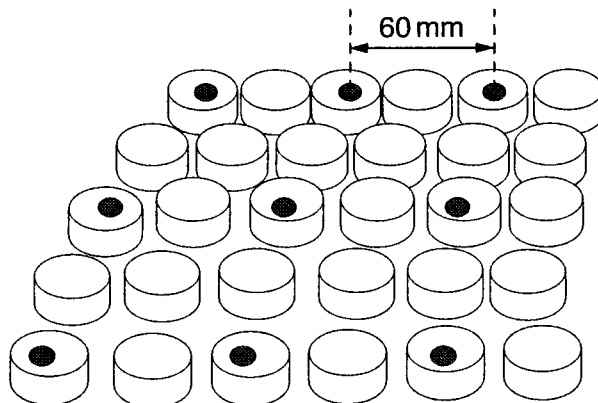

Fig. 10.2

It is suggested that the melted spots occur at displacement **antinodes** of a standing wave set up in the oven.

By considering the design of the microwave oven shown in Fig. 10.1, explain why there are **standing** waves inside the oven.

[2]

(c) Fig. 10.3 represents the variation in amplitude along part of one such standing wave.

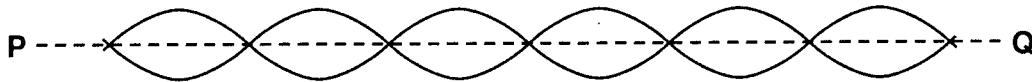

Fig. 10.3

- (i) On Fig. 10.3, mark a distance equal to one wavelength. Label it λ . [1]
- (ii) Along the line **PQ**, mark **two** positions where a melted spot might be expected to form. Label them **X** and **Y**. [1]
- (d) Suggest and explain how the outcome might be different for marshmallows being melted on a rotating turntable in the microwave oven.

[2]

[Total: 9]

- 11 Fig. 11.1 shows the two forces acting on a raindrop falling at velocity v through still air.

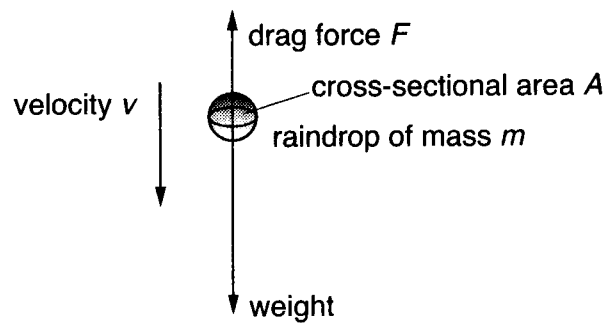

Fig. 11.1

- (a) The drag force F is related to the velocity v by the expression

$$F = K\rho Av^2$$

where K is a constant depending on the shape of the raindrop
 ρ is the density of air
 A is the cross-sectional area of the raindrop
 and v is the velocity of the raindrop.

- (i) Show that the unit of force N can also be written as kg m s^{-2} .

[1]

- (ii) Show that K has no units (is a dimensionless quantity).

[1]

- (iii) What can be said about the two forces acting on the raindrop when it is falling at constant velocity (terminal velocity) v_T ? Explain your reasoning.

[2]

- (iv) Show that the terminal velocity v_T of a raindrop of mass m is given by

$$v_T = \sqrt{\frac{mg}{K\rho A}}$$

where g is the gravitational field strength.

[2]

- (b) The table below shows information about two different sized spherical raindrops.

radius	cross-sectional area	weight
r	A	mg
$2r$	$4A$	$8mg$

Explain why, as the size of the drop increases from r to $2r$

- (i) the cross sectional area is increased by a factor of 4

[1]

- (ii) the weight is increased by a factor of 8.

[1]

- (c) Use the equation in (a)(iv), and the information in the table, to show that a raindrop of radius $2r$ will fall with a terminal velocity about 1.4 times greater than a raindrop of radius r .

[2]

[Total: 10]

[Section B Total: 40]